

# Installation, Operation, and Maintenance for Ford Water Meter Testing Equipment

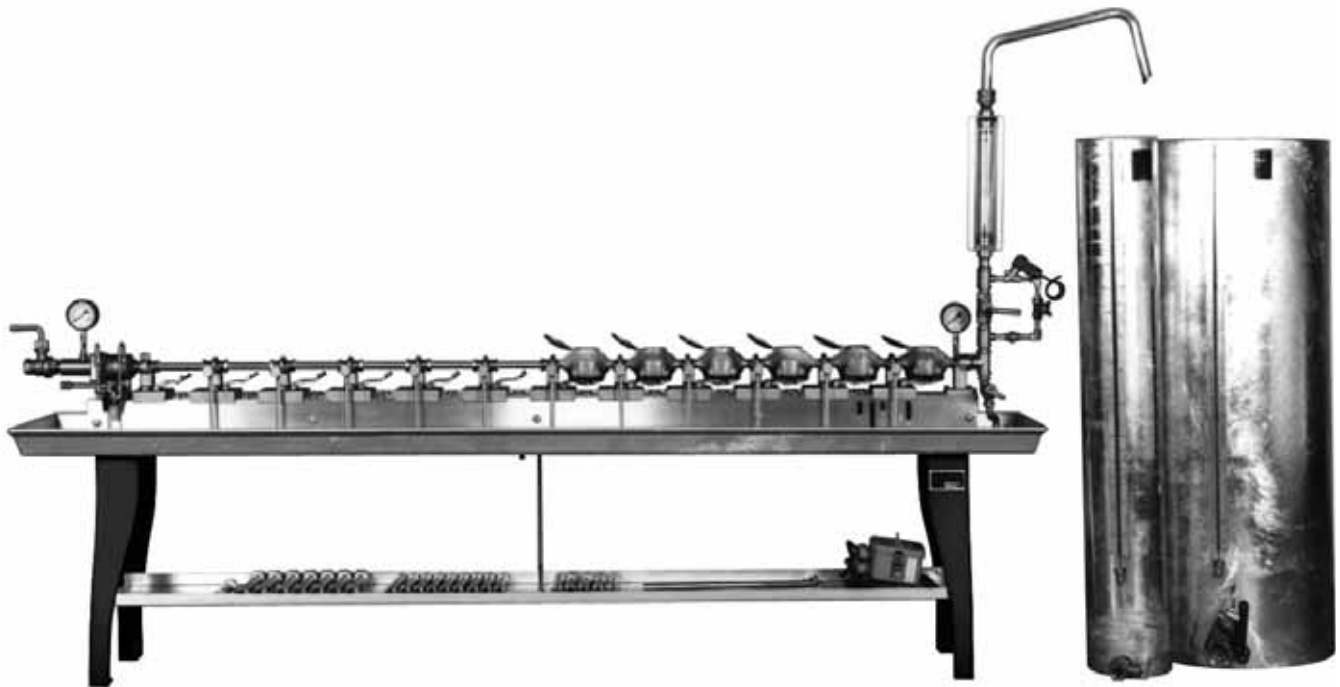

For Standard, Indianapolis, and Akron Series



# Installation, Operation, and Maintenance Instructions for Ford Water Meter Testing Equipment

CONTENTS	<i>page</i>
The Value of Unregistered Water . . . . .	3
Principle and Practice in Water Meter Testing . . . . .	4
Calibrated Tank Information . . . . .	4
The Advantages of Series Testing . . . . .	5
Test Bench Overview . . . . .	6 & 7
Optional Equipment for Ford Test Benches . . . . .	7
Setting the Bench . . . . .	8
Connecting the Plumbing . . . . .	9
Installing Calibrated Tanks . . . . .	10 & 11
Installing the Testrate Indicator and Gauges for Indianapolis and Standard Test Benches . . . . .	12
Operation of the Clamps, Gaskets and Adapters for the Standard Test Bench. . . . .	13
Operation of the Clamps, Gaskets and Adapters for the Indianapolis Test Bench . . . . .	14 & 15
The Ford Tester Clamp for 1-1/4", 1-1/2" and 2" Meters . . . . .	16
The Akron Test Bench for 1-1/2" and 2" Meters. . . . .	17
Operation of the Clamps, Gaskets and Adapters for the Akron Test Bench . . . . .	18
Akron Tester Clamp for 3", 4" and 6" Meters . . . . .	18
Installing and Operating the Testrate Indicator and Gauges for the Akron Test Bench. . . . .	19
Miscellaneous Parts and Electric Flow Control Unit Parts. . . . .	20
Installing and Operating the Optional Electronic Flow Control Equipment . . . . .	21 & 22
The Ford Test Bench Auto-Stop . . . . .	23
Parts for Standard Test Benches . . . . .	24
Parts for Indianapolis and Akron Test Benches . . . . .	25
Akron Meter Adapter Requirement Chart. . . . .	26 & 27
 Maintenance	
General Test Bench Maintenance . . . . .	28
Removal and Cleaning of Testrate Indicator Gauge Tube . . . . .	29 & 30
Replacement of O-Rings in Akron Test Bench Clamping Cylinders . . . . .	31
Replacement of O-Rings in Indianapolis Test Bench Clamping Cylinders . . . . .	31
Lubrication for the Rockwell Nordstrom® Outlet Flow Control Valve for Akron Test Benches . . . . .	32
Notes . . . . .	33
Accuracy Tests for New, Rebuilt, and Repaired Cold-Water Meters . . . . .	34 & 35
Warranty. . . . .	36

The Ford Meter Box Company considers all information found in this manual to be correct at the time of publication. Items and option availability, including specifications, are subject to change without notice. Please verify that your product information is current. Further information can be found in AWWA publication M6, Water Meters—Selection, Installation, Testing, and Maintenance.

NOTE: All Ford meter testing equipment is hand built and calibrated. It is important to properly install, operate and maintain this equipment for accurate, long-life performance. Please read all of these instructions before assembling meter testing equipment. If assistance is required, please contact The Ford Meter Box Company or an authorized distributor.

# The Value of Unregistered Water

Sales Price of Water		\$3.00 per 1000 Gallons			\$4.00 per 1000 Gallons			\$5.00 per 1000 Gallons		
Volume-Gallons		10,000	50,000	100,000	10,000	50,000	100,000	10,000	50,000	100,000
	4%	\$ 1.20	\$6.00	\$12.00	\$ 1.60	\$8.00	\$16.00	\$ 2.00	\$10.00	\$20.00
	6%	1.80	9.00	18.00	2.40	12.00	24.00	3.00	15.00	30.00
	8%	2.40	12.00	24.00	3.20	16.00	32.00	4.00	20.00	40.00
UNDER-	10%	3.00	15.00	30.00	4.00	20.00	40.00	5.00	25.00	50.00
REGISTRATION	12%	3.60	18.00	36.00	4.80	24.00	48.00	6.00	30.00	60.00
PERCENT	14%	4.20	21.00	42.00	5.60	28.00	56.00	7.00	35.00	70.00
	16%	4.80	24.00	48.00	6.40	32.00	64.00	8.00	40.00	80.00
	18%	5.40	27.00	54.00	7.20	36.00	72.00	9.00	45.00	90.00
	20%	6.00	30.00	60.00	8.00	40.00	80.00	10.00	50.00	100.00

## The Value of Unregistered Water

The testing of a water meter is very simple. It consists of checking the registration of the meter against the actual volume of water passing through the meter, as measured in an accurate volumetric tank or weighed on accurate scales.

The table above shows the value of water unregistered by meters with various percentages of slowness, and differing amounts of water drawn through the meter. In this example, water is valued at \$3.00 to \$5.00 per thousand gallons.

From the table it can be seen that with water at \$3.00 per thousand gallons, the return on investment for testing and repairing a meter 4% slow will be only \$12.00 with every 100,000 gallons of water used. It would take a large and active account to make frequent testing pay under these conditions.

On the other hand, with water at \$5.00 per thousand gallons, a meter failing to register 20% of the water passing through it would lose \$100 for the water works industry for every 100,000 gallons. Under these conditions, testing will have a much better return on investment.

## Surcharge for Sewage

The practice of charging for sewage disposal and treatment as a percentage of the water bill puts additional emphasis on meter accuracy. Surcharges can be as high as 150% of the water bill, with 100% surcharges common.

If a municipality has a surcharge of 100%, the effect is that the water meter is measuring the bill for sewage service in addition to its normal function of metering water. With a water rate of \$3.00 per thousand gallons and a surcharge of 100%, the meter is, in effect, measuring \$6.00 of revenue — all the more reason for accuracy.

If sewage service charges are to be based on meter readings, it would be only fair for the sewerage authority to carry part of the cost of meter testing and repairing.

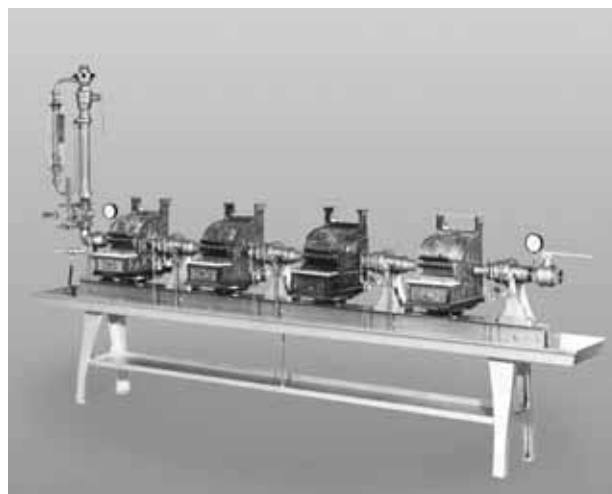

# Principle and Practice in Water Meter Testing

Meter accuracy may be defined as the quotient obtained by dividing the quantity registered during a test by the actual volume of water. Thus a meter registering nine gallons when 10 gallons are run through it has an accuracy of 9/10, or 90%. A meter registering 51 cubic feet on an actual volume of 50 cubic feet is 51/50, or 102% accurate. Meter accuracy is often expressed in percentage fast or slow. Thus a meter that records 95 gallons when 100 gallons are run through it under-registers or is slow by 5%. A meter registering 102 gallons on the same volume would be 2% fast. It is better, however, to express accuracy in actual terms, which would be 95% and 102% in these cases.

## The Two Ways Calibrated Tanks Can Be Used

When a single meter is being tested with a Ford Calibrated Tank there is a choice in the method and procedure. When the meter has a small test hand, the better procedure is to stop the flow when the meter indicates the passage of the test volume, such as one cubic foot, 10 gallons or 10 cubic feet. Thus the test hand makes one or more complete revolutions and is stopped exactly on a mark (see Figure 1). The percentage accuracy of the meter can then be read directly from the water level in the gauge glass of the calibrated tank as shown in the drawing.

It may be a little confusing to think that a water level above 100% in the tank indicates a slow meter. This is true because the meter has failed to register the amount of water that has passed through. It has under-registered, or is slow, by the percentage shown on the gauge strip.

When two or more meters are tested in series, the test flow is stopped when the tank gauge indicates the desired water level (see Figure 2). Then the accuracy of each meter is calculated by dividing the reading of the tank volume as described above and shown in Figure 2.

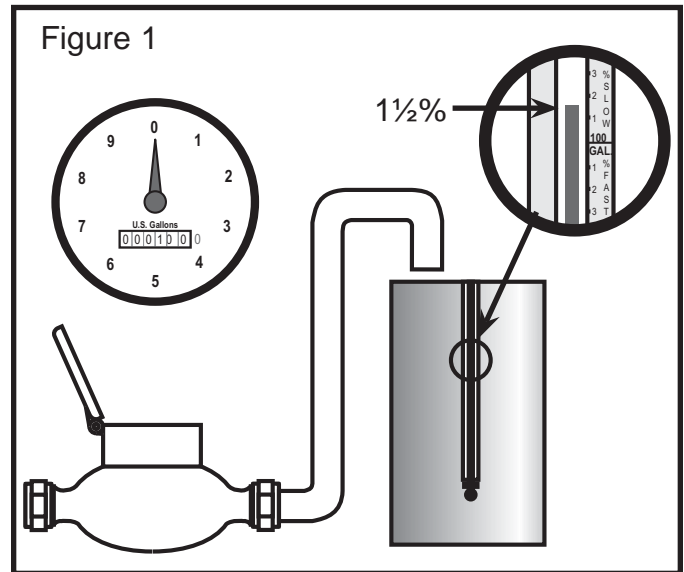

*In testing one meter at a time, the accuracy can be read directly from the tank if it is calibrated in percentages. In testing the above meter, the flow has been stopped when the meter has shown a registration of 100 gallons; the tank gauge shows the meter to be 98-1/2% accurate or 1-1/2% slow.*

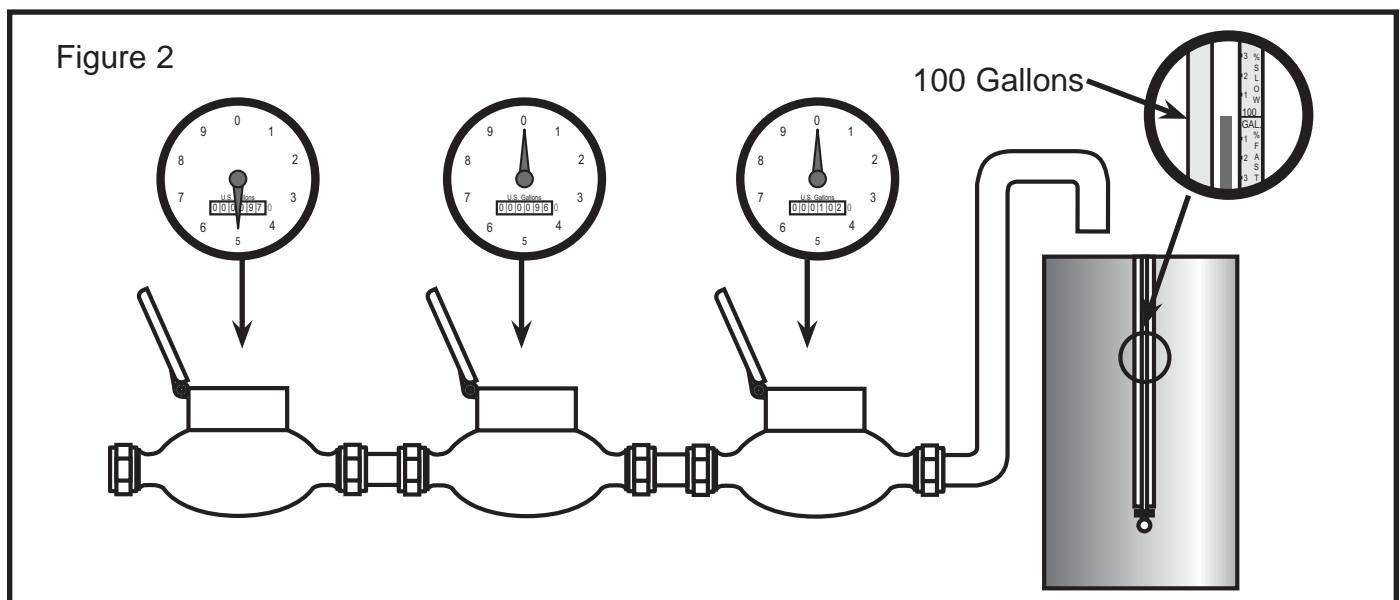

*In series testing, the test flow is stopped when the tank shows that the correct test volume has been run through the meters. In the above example, there are 100 gallons in the tank and the meters read, from left to right, 97-1/2 gallons, 96 gallons and 102 gallons. In other words, these meters are registering 97-1/2%, 96% and 102%.*

# The Advantages of Series Testing

## How many meters should be tested in series?

Except in small meter shops where only a few meters are tested in a day, the advantages of series testing justify the small additional cost for equipment and space required.

In series testing, two or more meters are connected in line. The same water is run through all the meters and measured in a tank. The same water and tank are used for the test, and the time for testing is the same as for one meter. The economical number of meters to test in series depends on the following factors:

1. *The number of meters to be tested in one day* – It may be cost-saving for a small utility to accumulate meters for several weeks and then test in series, depending on factors below.
2. *The additional cost of the added equipment and space required* – The cost for multiple units on test benches is nominal. Meter shops usually have the space for a multiple unit test bench. Multiple unit benches can decrease time and expense otherwise required to test each meter individually. Series testing pays a good return on the investment.
3. *The water pressure available* – It should provide an ample flow through all meters to flush out air and offer a reasonable rate for the high-flow test, say 7 to 10 gpm for 5/8" meters.
4. *The value of the water and manpower saved* - Some meter

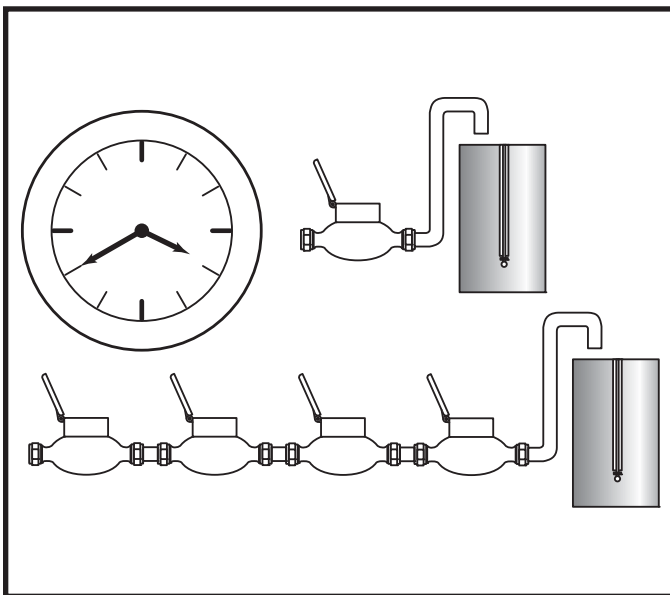

*The same water and tank will test two, four, eight or more meters in the same time as one meter. The savings in series testing can be substantial and can pay a good return on the modest additional investment.*

shops repump water for testing as an economy measure. In one meter shop the switch from 5-unit to 10-unit benches increased production of the department over 40% and paid a magnificent return on the added investment.

There is no good rule of thumb to apply in deciding on the correct number of meters to be tested in series because of the above variables. It might be considered good practice and good economics to start with one testing unit for every five meters to be tested in a day, gradually decreasing the ratio to 10 units for 100 meters.

For testing a very large number of meters, both Standard and Indianapolis Test Benches are available with two rows of test units, with each row having separate piping and valves. Either row may run separately or both in series. As many as 24 meters can be tested at one time.



*Testing 12 meters in series on an Indianapolis Test Bench. Electric control closes the valves at completion of test.*

# Test Bench Overview

## Standard Test Bench

### Includes the following:

1. Adapters and gaskets for 5/8", 5/8"x3/4", 3/4" and 1" meters
2. Ball valve at inlet and outlet
3. Testerate Indicator
4. Pressure gauges at inlet and outlet of each row
5. Bleeder or adjusting valve at outlet of each unit
6. Drain valve at outlet of bench
7. 18" copper swinging discharge pipe at outlet
8. Idlers for all but one meter testing station

Inlet valve is tapped for a 1" pipe connection.

Options available for benches listed on page 7.



Tanks ordered separately

Catalog Number		Number of Units	Length of Pan	Width of Pan	Approx. Ship. Wt. Lbs.
Flow Left to Right	Flow Right to Left				
<b>Single Row Standard Test Benches</b>					
1STB-LR	1STB-RL	1	22"	14"	200.0
2STB-LR	2STB-RL	2	38"	16-1/2"	290.0
3STB-LR	3STB-RL	3	54"	16-1/2"	360.0
4STB-LR	4STB-RL	4	70"	16-1/2"	430.0
5STB-LR	5STB-RL	5	86"	16-1/2"	490.0
6STB-LR	6STB-RL	6	102"	16-1/2"	530.0
8STB-LR	8STB-RL	8	134"	16-1/2"	610.0
<b>Double Row Standard Test Benches</b>					
8STB-DR-LR	8STB-DR-RL	8	76"	20"	—
16STB-DR-LR	16STB-DR-RL	16	140"	20"	—

## Indianapolis Test Bench

### Includes the following:

1. Hydraulic cylinder at inlet for clamping of meters
2. Adapters and gaskets for 5/8", 5/8"x3/4", 3/4" and 1" meters
3. Ball valve at inlet and outlet
4. Testerate Indicator
5. Pressure gauges at inlet and outlet of each row
6. Bleeder or adjusting valve at outlet of each unit
7. Drain valve at outlet of bench
8. 18" copper swinging discharge pipe
9. Idlers for all but one meter testing station

Inlet valve is tapped for 1" pipe connection.

Options available for benches listed on page 7.

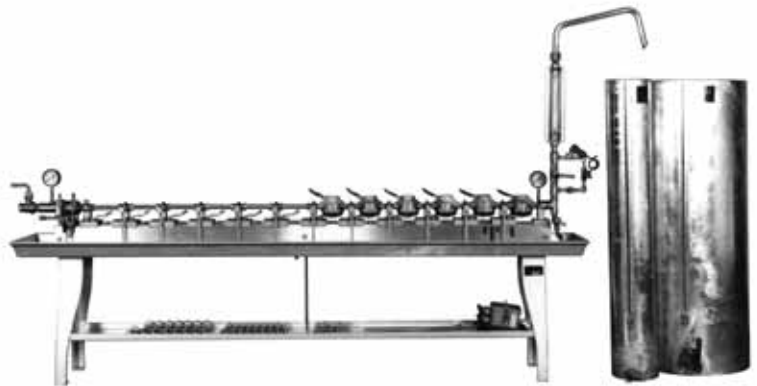

Tanks ordered separately

Catalog Numbers		Number of Units	Length of Pan	Width of Pan	Approx. Ship. Wt. Lbs.
Flow Left to Right	Flow Right to Left				
<b>Single Row Indianapolis Test Benches</b>					
110ITB-LR	110ITB-RL	10	102"	16-1/2"	650.0
112ITB-LR	112ITB-RL	12	118"	16-1/2"	700.0
<b>Double Row Indianapolis Test Benches</b>					
120ITB-DR-LR	120ITB-DR-RL	20	108"	20"	1000.0
124ITB-DR-LR	124ITB-DR-RL	24	124"	20"	1000.0

**Note:** For configurations not listed above, contact the factory.

**Note:** The Double Row Indianapolis Test Bench is plumbed so two rows can be tested in series, or each row tested separately.

The 110 or 112 Indianapolis Test Bench can be used for efficient testing of 1" and smaller meters. The 110ITB style bench holds six 1", seven 3/4", ten 5/8" or 5/8"x3/4" meters. The 112ITB style bench holds eight 1", ten 3/4", twelve 5/8" or 5/8"x3/4" meters. All adapters are included, and the benches can be changed from one size to another in less than five minutes. Each change must be complete; these benches are not functional to a mixture of meter sizes.

# Test Bench Overview

## Akron Test Bench

### Includes the following:

1. Hydraulic clamping cylinder and adjustable pedestal for each meter test space
2. 2" valve at inlet and outlet
3. Bleeder or adjusting valve at outlet of each unit
4. Pressure gauges at inlet and outlet of each row
5. Double Range Testrate Indicator with flow adjusting valve at bench outlet
6. All necessary adapters and gaskets for 1-1/4", 1-1/2" and 2" meters
7. 2" Idlers for all but one meter testing station
8. Globe style blow-off valve at outlet of bench

Inlet valve is tapped for 2" pipe connection.

**Note:** Discharge pipe not included due to wide variation in delivery piping available. Optional adapters for smaller meters listed on page 17. Other options listed below.

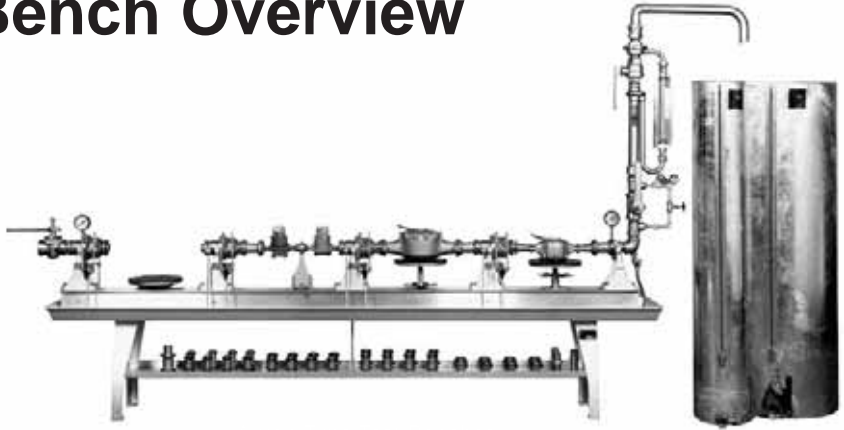

Tanks ordered separately

CATALOG NUMBER		No. OF UNITS	MAXIMUM LENGTH OF METER	LENGTH OF PAN	WIDTH OF PAN	APPROX. SHIPPING WT. LBS.
FLOW LEFT TO RIGHT	FLOW RIGHT TO LEFT					
1SATB-LR	1SATB-RL	1	17"	54"	16-1/2"	550.0
2SATB-LR	2SATB-RL	2	17"	70"	16-1/2"	700.0
3SATB-LR	3SATB-RL	3	17"	102"	16-1/2"	880.0
4SATB-LR	4SATB-RL	4	17"	134"	16-1/2"	990.0
1LATB-LR	1LATB-RL	1	21"	54"	16-1/2"	600.0
2LATB-LR	2LATB-RL	2	21"	86"	16-1/2"	750.0
3LATB-LR	3LATB-RL	3	21"	118"	16-1/2"	940.0
4LATB-LR	4LATB-RL	4	21"	134"	16-1/2"	1090.0

**Note:** For configurations not listed above, contact the factory.

## Options Available for Ford Test Benches

### Calibrated Water Tanks

Ford offers a wide variety of water tanks for use with test benches.

### Electronic Control Unit

Allowing the operator to test meters with an unattended test bench, the ECU (pages 21-22) safely monitors and stops the flow of water automatically. Select -ECU in the part number when ordering with a test bench. Works for low flows only.

### Auto-Stop

Designed to automate testing operations and provide a wide range of flow tests on water meter test benches, Ford offers the Auto-Stop (page 23). Performing up to three user-adjusted flow rate tests, the Auto-Stop utilizes the joystick control to stop and start tests as well as drain the test tank. With sensors on each tank, the test is terminated automatically once the water level reaches pre-set tank levels.

### Tester Clamp

The optional Tester Clamp quickly adapts to any Ford Test Bench to allow for testing large meters at flow rates up to 36 gpm. Order catalog number TC for Standard or Indianapolis Benches (page 16), and TC-A for Akron Benches (page 18).

### AMS

Automate the testing process with the next generation Automated Measuring System (AMS). This valuable innovation revolutionizes meter testing by automating manual operations. Order by adding -AMS to the end of the part number. See catalog section K or contact factory for more information.

### Extended Length Discharge Pipe

For positioning water tanks further from the bench, an optional 24" long discharge pipe is available. Order catalog number 9557 (18") or 9558 (24").

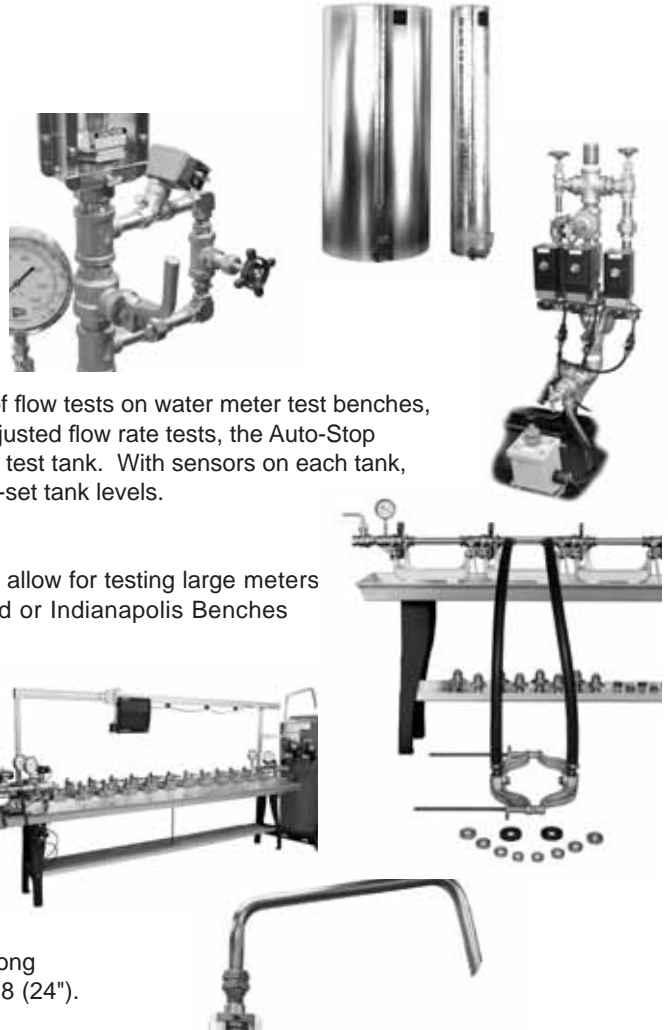

# Setting the Bench

- Figure #1 illustrates the layout of a typical meter shop. Before setting the testing equipment, review this layout and select a location based on the following:
  - The supply of water to the inlet of the bench should provide for large-flow tests, if required. Connect the testing equipment to a supply line at least one size larger than the inlet valve (example: 1-1/4" inlet pipe to 1" inlet valve).
  - The drain hole in the end of the pan should run to the tank sump or to a floor drain.
  - An air chamber or expansion tank, as shown in Figure #2, just ahead of the inlet valve will reduce water hammer when large-flow tests are stopped quickly, preventing possible damage to meters or piping.
- Uncrate and remove any packing tape from the test bench and calibrated tank and position them as desired. Unpack and sort all supplied adapters and equipment; check for damage. If any item is damaged in transit, notify the transportation company and The Ford Meter Box Company at once.

The bench should be installed on a level floor. As shown in Figure #3, the bench should be level through axis **A-B**. This will allow the slope on the pan to drain water to outlet **C**. The tanks must be set so that the discharge from the bench at **D** will go into the tank.

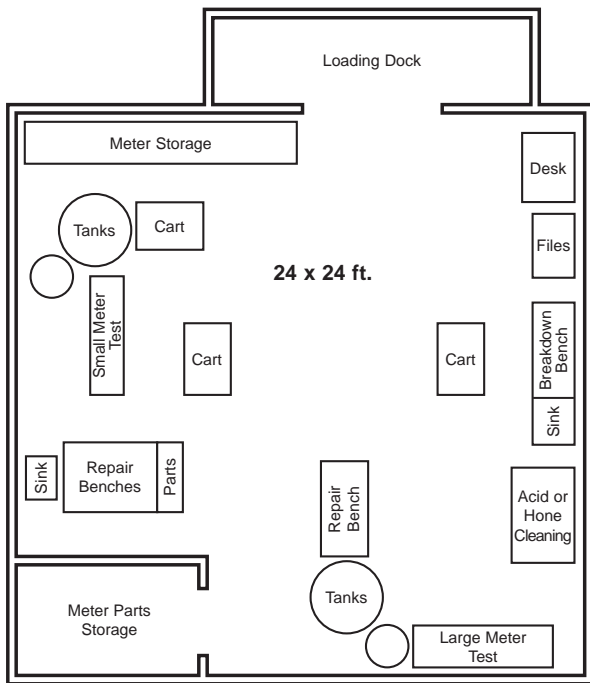

Fig. #1

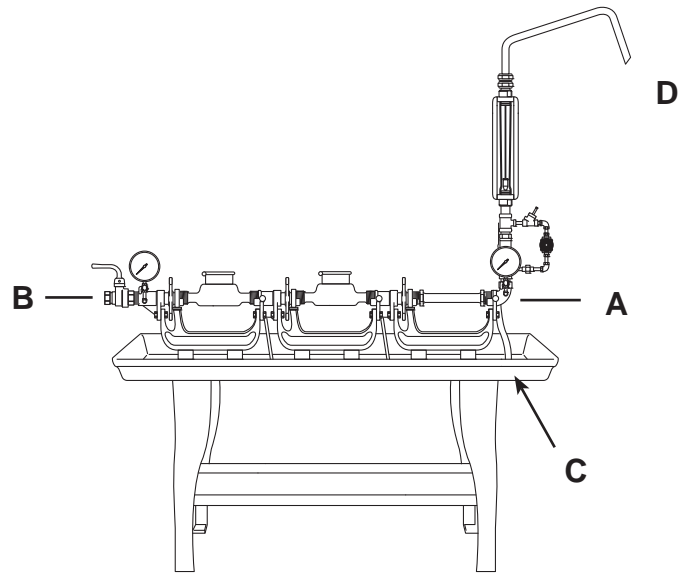

Fig. #3

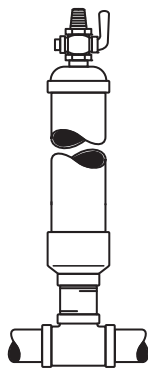

Fig. #2



# Connecting the Plumbing

Connect water supply piping to the inlet valve of the bench when the bench and tank position are set. See Figure #4.

NOTE: The Standard Bench and Indianapolis Bench have an inlet ball valve tapped for a 1" pipe connection. The centerline of the inlet valve is 34-1/2" above floor level for the Standard Bench, 34" for the Indianapolis Bench.

The Indianapolis Bench requires a quarter-inch pipe leading to the four-way piston-operated valve on the inlet clamping cylinder. This valve operates the inlet clamping cylinder that serves all testing stations. Connect this quarter-inch line to the water supply piping ahead of the inlet valve.

For the Akron Bench the inlet ball valve is tapped for a 2" pipe connection, 40-1/4" above the floor level. A quarter-inch pipe leading to the four-way piston-operating valve near the inlet cylinder is required to operate the clamps that hold the idlers or meters. Connect this quarter-inch line to the water supply piping ahead of the inlet valve; there is one valve for each test station.

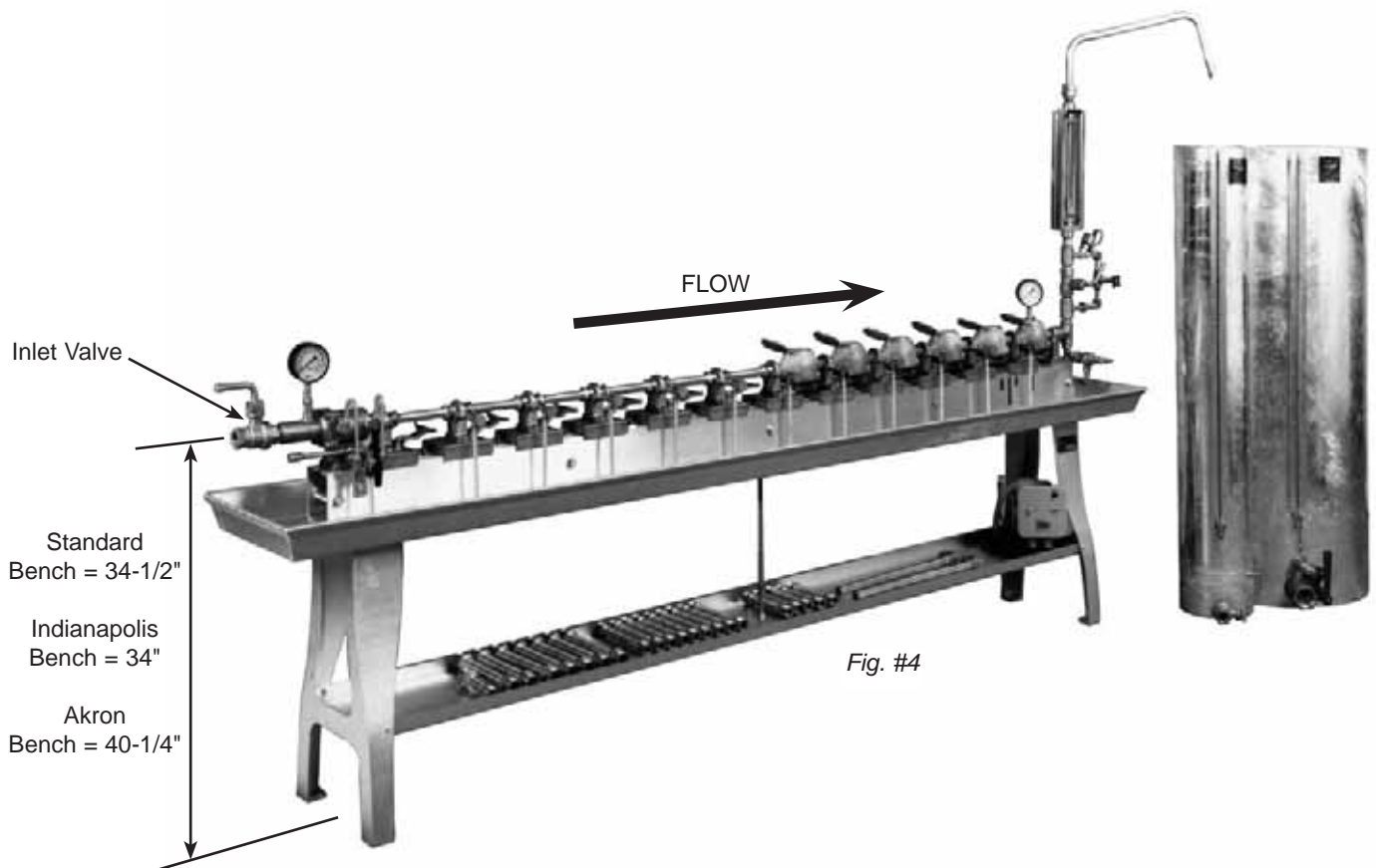

# Installing Calibrated Tanks

Calibrated volumetric tanks are simple and sturdy pieces of equipment but require careful installation and proper operation. Position tanks so the test bench discharge pipe swings over the tank for delivery of the test stream. Drainage plumbing for the tank must be equal to or larger than the size of the outlet valve at the bottom of the largest tank. Once the calibrated tanks are plumb, secure them to prevent movement. Be certain the tanks remain perfectly plumb after securing them.

1. If possible, mount the tanks on a substantial concrete floor, or ideally on a concrete pedestal about 10" in height. This additional height will place the water level at test-volume in a conveniently readable position. The layout should permit the operator to observe water draining from the tank valve and the water level in the tank sight gauge while operating the outlet flow control valve. Figures #6 and #7 (next page) illustrate top views of two suggested layouts.
2. **TANKS MUST BE PLUMB!** Plumb with a plumb-line on the aluminum calibration strip. Plumb the tanks in two directions as shown in Figure #5. Use the front and the side of the calibration strip for plumb points.

**Note:** Tanks are calibrated with O.E.M. drain valves. Alternate valve replacement may cause inaccurate test results.

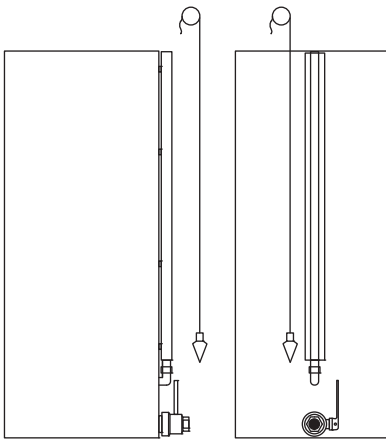

Fig. #5



Pictured are 10-gallon and 100-gallon tanks (10-GF and 100-GF), ordinarily used together, as are the 1-cubic foot and 10-cubic foot tanks (1-F and 10-FG). In nearly all cases, two tanks are recommended. The smaller for low and intermediate tests and the larger for high-flow tests.

Catalog Number	Nominal Size	Dia.	Height	Calibration Points	Size Discharge	Approx. Shipping Wt. Lbs.
1-F	1 cu. ft.	7"	60"	1 & 1/2 cu. ft.	1"	105.0
10-GF	10 gal.	9"	60"	10 & 5 gal. - 1 cu. ft.	1"	120.0
20-GF	3 cu. ft.	13"	60"	3 & 2 cu. ft. - 20 & 10 gal.	1-1/2"	130.0
10-FG	10 cu. ft.	22"	60"	10 & 5 cu. ft. - 70 & 30 gal.	1-1/2"	200.0
100-GF	100 gal.	26"	60"	100 & 50 gal. - 10 cu. ft.	2"	240.0
50-F	50 cu. ft.	47"	72"	50 & 25 cu. ft.	3"	690.0
* 500-G	500 gal.	54"	72"	500 & 250 gal.	3"	800.0
* 100-F	100 cu. ft.	67"	72"	100 & 50 cu. ft.	3"	1230.0
* 1000-G	1000 gal.	73"	78"	1000 & 500 gal.	3"	1600.0
25-L	25 liters	7"	60"	<b>AS SPECIFIED BY PURCHASER</b>	1"	110.0
50-L	50 liters	9"	60"		1"	117.0
100-L	100 liters	13"	60"		1-1/2"	190.0
150-L	150 liters	16"	60"		1-1/2"	215.0
200-L	200 liters	19"	60"		1-1/2"	275.0
400-L	400 liters	26"	60"		2"	375.0
500-L	500 liters	30"	60"		2"	420.0
600-L	600 liters	32"	60"		2"	480.0
1000-L	1 cu. meter	39"	72"		3"	505.0
* 2000-L	2 cu. meters	54"	72"		3"	970.0
* 3000-L	3 cu. meters	67"	72"		3"	1500.0
* 4000-L	4 cu. meters	73"	78"		3"	1925.0
* 5000-L	5 cu. meters	84"	78"		3"	2550.0

\* Painted steel construction

# Installing Calibrated Tanks

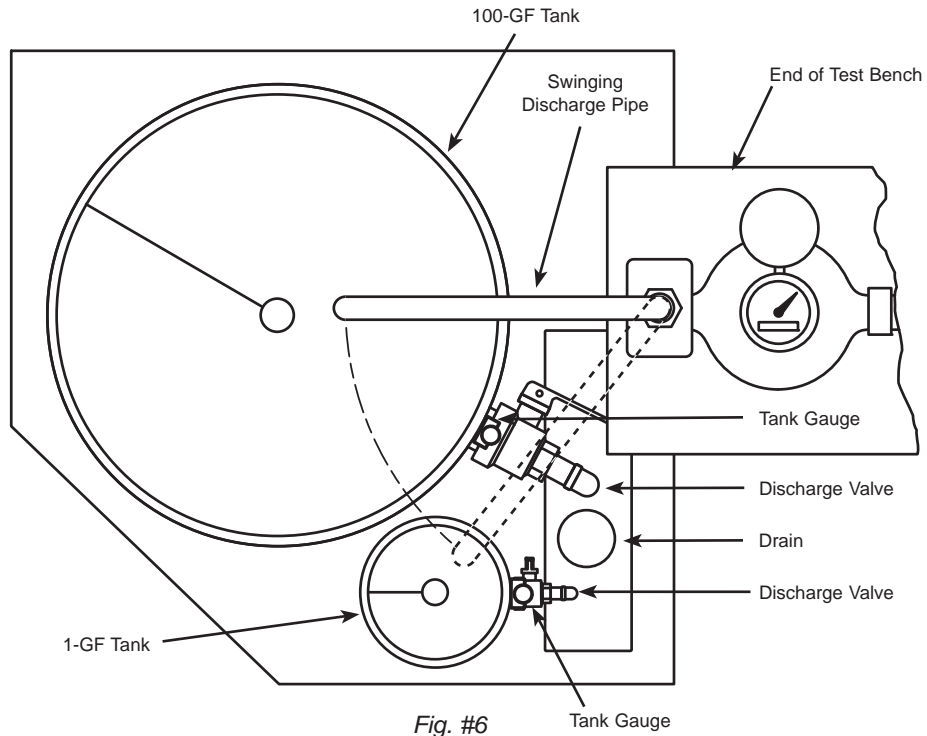

Standard layout with sight gauges directly above drain valves

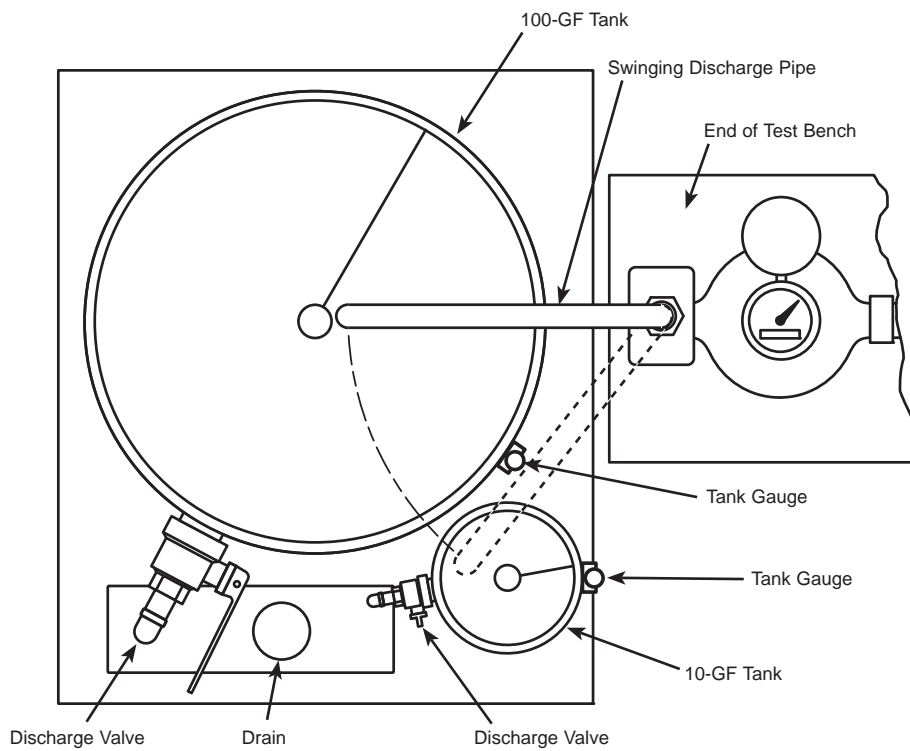

Alternate layout with sight gauges rotated away from drain valves

# Installing the Testerate Indicator and Gauges

## Indianapolis and Standard Test Benches

The Ford Testerate Indicator is a precision instrument and requires careful handling for best results. The glass tube will withstand a pressure of 150 lbs. per square inch; however, the glass is not guaranteed against breakage in service. The glass tube is surrounded by the Testerate Indicator frame and two clear plastic covers. Do not operate the unit without the covers. If the unit is damaged in transit, notify the transportation company and The Ford Meter Box Company at once. See Caution below.

### Unpacking

The indicator has a piece of flexible plastic inserted to keep the rotor from moving during shipment. To remove the plastic tubing, just pull it from the upper (outlet) end of the indicator. After removing the plastic tubing, the indicator is ready for installation.

### Installing

1. The Testerate Indicator is tapped for 1" pipe at both ends. The piping should be secure and not subject to vibration.
2. Install the Testerate Indicator on the outlet of the bench in a vertical position, with the large end of the glass tube on top. See the bottom of the page for Testerate Indicator operation.
3. Connect the swinging discharge pipe to the indicator so the discharge flows into the calibration tank as in figure #8. In order to prevent twisting the Testerate Indicator frame, use two wrenches to connect the swinging discharge pipe assembly. Hold one wrench on the brass fitting on the top of the Indicator and use the other to tighten the swing discharge pipe assembly.
4. The test bench includes two pressure gauges. Screw the gauges into the pet cocks at each end of the bench (see Fig #8). NOTE: The pressure gauges supply information on pressure drop across the bench and are not necessary for testing meters.

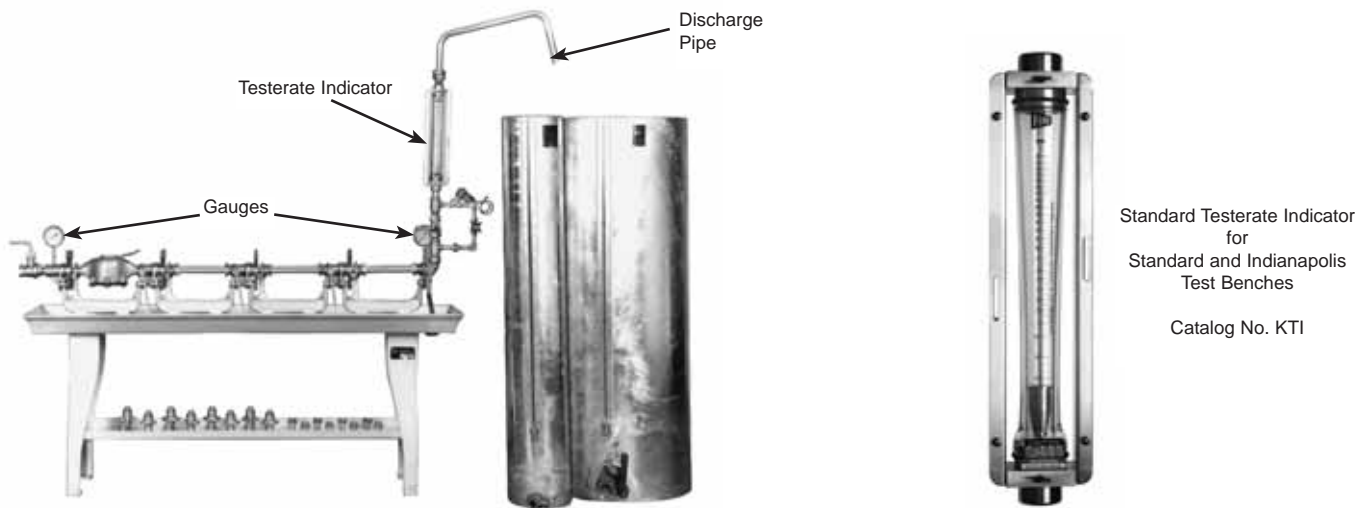

Fig. #8

---

## Important Information for Proper Operation of Testerate Indicator

**CAUTION:** The Testerate Indicator is a delicate instrument and is easily damaged by abuse or improper use. One of the common ways to damage the Testerate Indicator is to have the blow-off valve closed when the inlet valve is opened. This compresses the air in the meters. If the outlet valve is then opened abruptly, the compressed air rushes through the Testerate Indicator causing violent movement of the rotor inside the glass gauge tube. This could cause damage to the indicator.

When operating the test bench, make sure the blow-off valve is open while opening the inlet valve. Do not close the blow-off valve until the system has purged itself of air. When testing begins, open the outlet valve slowly as some air will remain between the outlet valve and Testerate Indicator.

# Operation of the Clamps, Gaskets and Adapters For the Standard Test Bench

1. The Standard Test Bench tests 5/8" through 1" water meters. To test water meters smaller than 1", install the adapters for the meter sizes you plan to test. Screw adapters into the inlet and outlet of each testing unit. Be sure to install all gaskets.
2. Clamp the meters in place, using the hand operated handles (Fig. #9). Always test meters of the same size at the same time.
3. Open the blow-off valve at the outlet of the bench and close the outlet valve going to the Testerate Indicator. Turn on the inlet valve and purge all the air from the meters. Then close the blow-off valve and open the outlet valve slowly to purge all air from the complete test bench system.
4. Close the outlet valve and adjust the meters to an easily recorded point using the bleeder valves. Adjust the outlet/last meter first, moving to the next (upstream) meter with each successive adjustment.
5. See page 12 for Testerate Indicator operation.
6. Be sure the calibrated tank is empty and the tank drain valve is closed. Now you are ready to begin testing the meters.

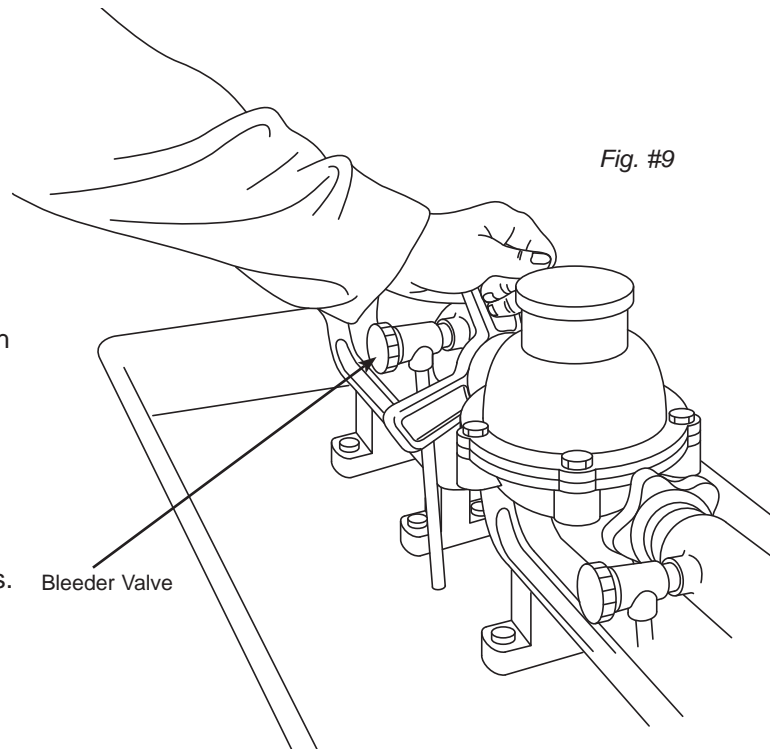

Fig. #9

Clamping a Meter in a Standard Test Bench

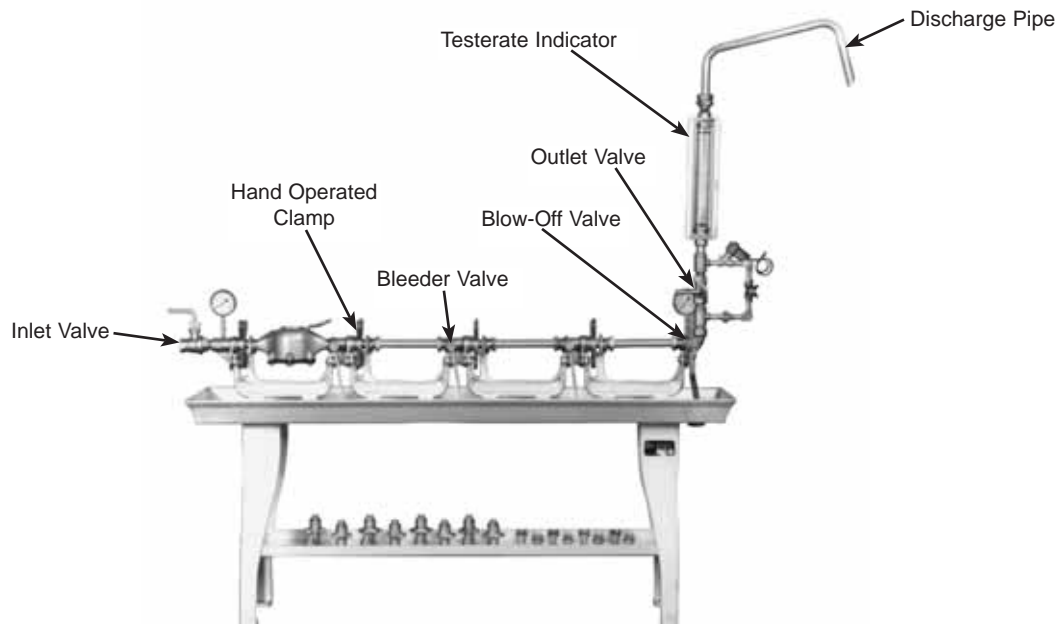
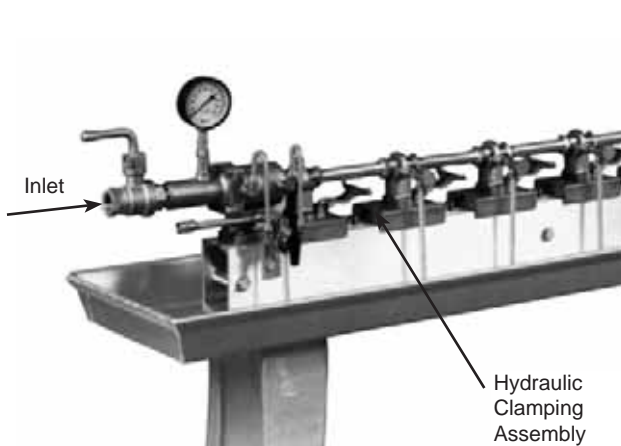

Fig. #10

# Operation of the Clamps, Gaskets and Adapters For the Indianapolis Test Bench

1. The Indianapolis Test Bench is designed to test water meters in sizes 5/8" through 1". Place adapters into the inlet and outlet of each unit of the bench to adapt to the smaller sized meters. To test water meters, first install the adapters for the meter sizes you plan to test. Be sure to install all gaskets.
2. Clamp the meter in place, using the four-way valve (Fig. #11) that operates the hydraulic clamping cylinder (Fig. #12). Always test meters of the same size at the same time.
3. Open the blow-off valve at the outlet of the machine and close the outlet valve going to the Testerate Indicator. Turn on the inlet valve and purge all the air from the meters. Next, close the blow-off valve and open the outlet valve slowly to purge all air from the complete test bench system.
4. Close the outlet valve and adjust the meters to an easily recorded point using the bleeder valves. Adjust the last meter first, moving to the next (upstream) meter with each successive adjustment.
5. See page 12 for Testerate Indicator operation.
6. Be sure the calibrated tank is empty and the tank drain valve is closed. Now you are ready to begin testing the meters.



The Indianapolis Test Bench

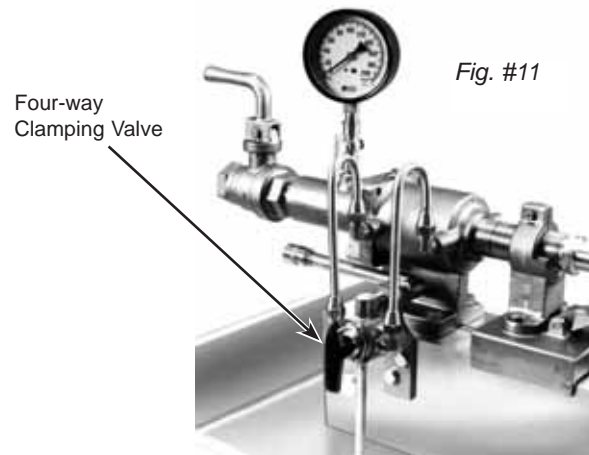

The Four-way Hydraulic Clamping Valve on Indianapolis Bench

The drawing below shows the hydraulic cylinder, which is controlled by a small four-way valve; also shown is one dolly with spring fork and bleeder valve, which is used to adjust the reading of each meter to an exact mark before the test is started.

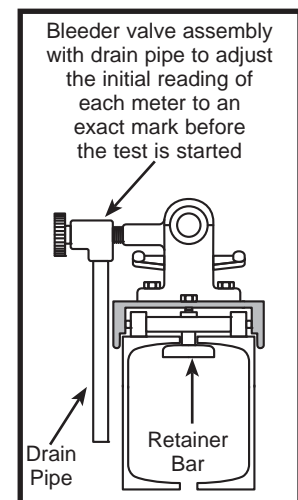
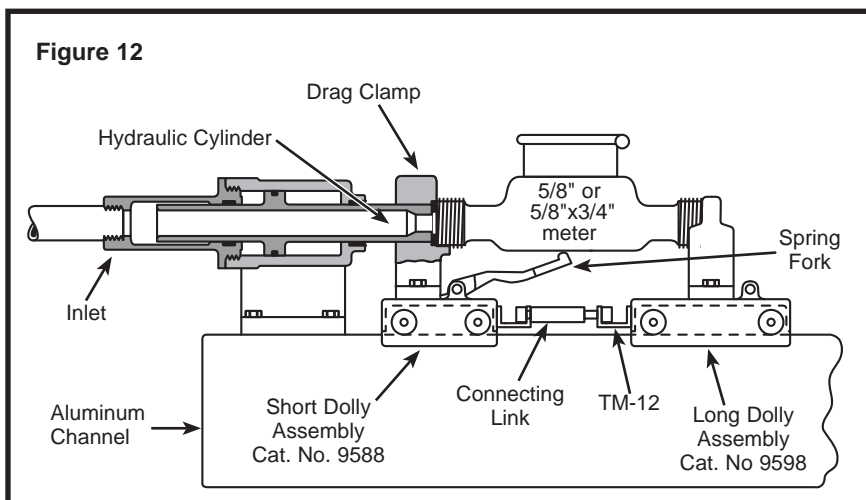

# Operation of Gaskets and Adapters For Indianapolis Test Bench

## For 5/8" Meters

1. Check to see that the split-ring saddles are firmly in place in the dolly saddles.
2. Check to see that all gaskets are in place.
3. Place small split-ring in the saddle at the outlet end of the bench.
4. Use the short links between all dolly boxes.
5. Place the L-shaped holdback pin into the hole marked 5/8" or 5/8"x3/4" on the top of the channel track near the outlet end.
6. Clamp up to 12 meters into position by turning the lever handle on the four-way valve.

## For 5/8"x3/4" Meters

*To set up the bench to hold full 5/8"x3/4" meters:*

1. Remove the 5/8" split-ring saddles (using a pick or a punch in the hole) and insert the 3/4" ring saddles and gaskets.
2. Place the holdback pin into the hole that is marked 5/8" or 5/8"x3/4".
3. Use the short links between all dolly boxes.
4. Check to see that all gaskets are in place.
5. Place the meters in position.
6. Clamp up to 12 meters into position by turning the lever handle on the four-way valve.

## For 3/4" Meters

*To set up the bench to hold full 3/4" meters (9" long):*

1. Remove holdback pin from the hole in the top of the channel track. Next, remove all connecting links from between the dolly boxes. (Note that the short links are used with 5/8" or 5/8"x3/4" meters, medium links with the 3/4" meters, and the long links with 1" meters.)
2. Slide two dolly boxes toward the outlet end of the channel track and lift them off. Dolly boxes will lift off channel track when their drain pipe is even with the letter words "Removal Hole" marked on the channel track.
3. Place medium length links between the dolly boxes remaining on the channel track.
4. Replace holdback pin in the hole marked 3/4".
5. Put the 3/4" size split-ring saddles and gaskets in position to hold 3/4" meters properly.
6. Up to ten 3/4" meters may then be clamped into position.

## For 1" Meters

*To set up the bench to hold full 1" meters (10-3/4" long):*

1. Remove the holdback pin from the hole in the top of the channel track. Remove all the connecting links from between the dolly boxes.
2. Remove a total of three dolly boxes by sliding them toward the outlet end of the channel track and lifting them off. (See instruction Number 2 for the 3/4" meters.)
3. Place the longest links between the dolly boxes.
4. Replace the holdback pin in the hole marked 1".
5. Remove all the split-ring saddles and place 1" gaskets in position.
6. Use the special short idler pipe in the last open unit at the outlet of the test bench.
7. Up to eight 1" meters may be clamped into position.

**Note:** Use idler pipes in place of meters when testing less than the maximum number or for set-up purposes.  
Use 5/8"x3/4" idlers when testing 5/8" meters.

# The Ford Tester Clamp

## For Standard and Indianapolis Test Benches

### To Adapt 1-1/4", 1-1/2" and 2" Meters

The optional Tester Clamp (Catalog No. TC) quickly adapts any Standard or Indianapolis Test Bench to test 1-1/4", 1-1/2" and 2" meters. The bar with hoses attached is inserted into any unit, the same as a 1" meter, and the large meter is then connected between the clamp halves on the floor – or in a pan – in front of the test bench. The flow capacity is adequate for testing 2" meters at minimum and intermediate flow tests. For the meter shop with a limited number of large meters, the Tester Clamp, used with a Standard or Indianapolis Bench, provides adequate facilities. Note: Intermediate flow tests may not be accurate due to specific meter application requirements, which may include straight runs before and after the meter.

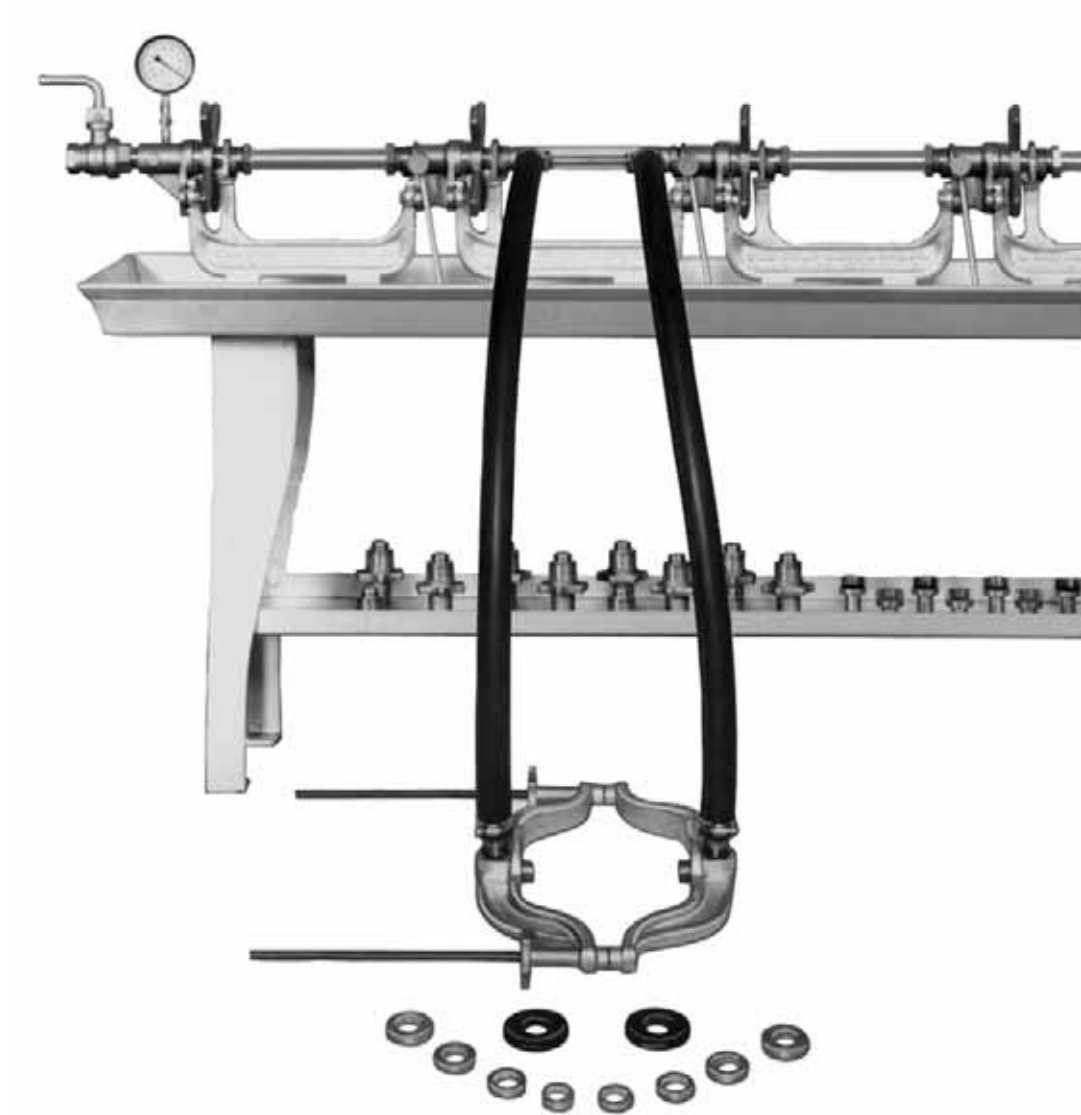



# The Ford Akron Test Bench

Akron Test Benches are designed primarily for testing 1-1/4" through 2" meters but can hold smaller sizes with optional adapters. Benches are available for testing from one to four meters at a time. Each unit includes an adjustable plate or table for supporting and positioning the meter and a hydraulic cylinder for clamping the meter water tight. Akron Benches are made in two models: the S style for testing up to 2" disc type meters 17" long and the L style for up to 2" compound meters 21" long.

Akron Test Benches include adapters for 1-1/4" flanged meters, and 1-1/2" and 2" flanged and tapped meters. Optional adapters are available for 1" (Catalog Number AD-4), 3/4", 5/8"x3/4" and 5/8" meters (Catalog Number AD-3S or AD-3L) at an additional cost. In testing the latter two sizes (both 7-1/2" long) the meters are placed two in each unit, with a removable center support (HT-10 found on page 26). 3/4" meters are placed two in each unit on the L style bench and only one per unit on the S style. If a large number of 5/8" through 1" meters are to be tested, Ford recommends a Standard or Indianapolis type bench. Akron Benches are designed for only occasional testing of small meters.

Pictured below is the No. 4 Akron Test Bench (4SATB-LR) with Double Range Testerate Indicator and with the testing stations arranged to demonstrate versatility of adapting to various sizes of meters. The first unit at the left is prepared to receive a 2" disc meter. The second unit contains two 5/8"x3/4" meters; the middle support is removable. The third unit contains a 1-1/2" disc meter with flanged ends. The fourth unit at the right is adapted to receive a 1" meter. The configuration shown below is for illustration purposes only. Actual testing requires the same size meters or idlers. Benches are not functional with a mixture of meters. The electric flow control unit at the bench outlet (shown below) is available and is convenient for stopping unattended slow flows at end of test.

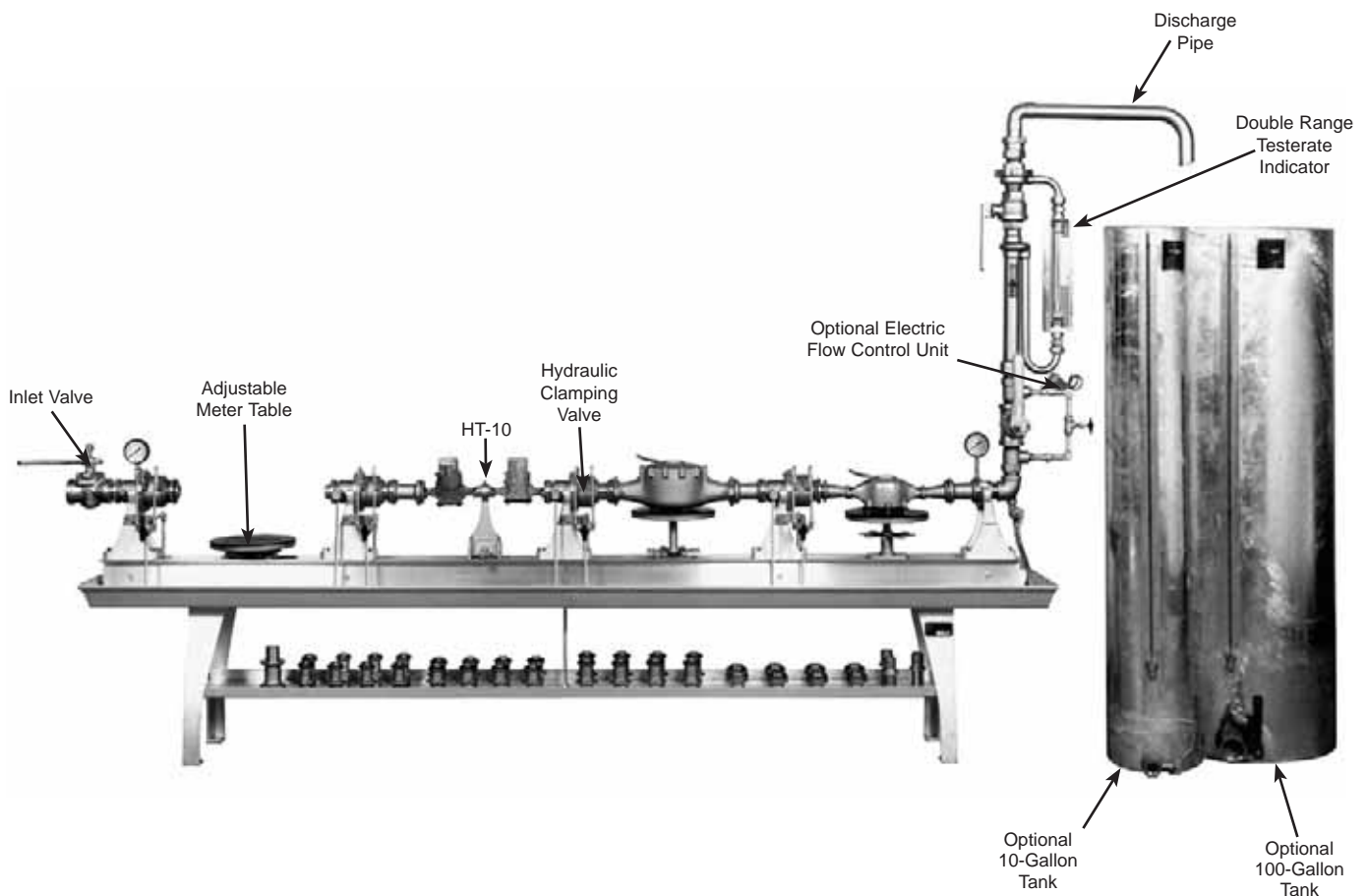

**Note:** Actual test requires the same size meters or idlers. Benches are not functional with a mixture of meters.

# Operation of the Clamps, Gaskets and Adapters For the Akron Test Bench

1. The Akron Test Bench is designed to test water meters in sizes 1-1/4" through 2". Place adapters into the inlet and outlet of each station of the bench to adapt to the smaller sized meters. Be sure to install all gaskets. See page 26 and 27 for various adapter requirements. Optional adapters are available for 1" (Catalog Number AD-4), 3/4", 5/8"x3/4" and 5/8" meters (Catalog Number AD-3S or AD-3L) at an additional cost.
2. Clamp the meter in place, using the four-way valve (Fig. #13) that operates the hydraulic clamping cylinder. For a more accurate test:
  - 1) Always test meters of the same size at the same time.
  - 2) Use idlers upstream and downstream of turbine meters.
  - 3) Place multi-jet meters upstream of positive displacement meters.
3. Open the blow-off valve at the outlet of the machine and close the outlet valve going to the Testerate Indicator. Turn on the inlet valve and purge all the air from the meters. Then close the blow-off valve and open the outlet valve slowly to purge all air from the entire test system.
4. Close the outlet valve and adjust the meters to an easily recorded point using the bleeder valves. Adjust the outlet/last meter first, moving to the next (upstream) meter with each successive adjustment.
5. Be sure the calibrated tank is empty and the tank drain valve is closed. Now you are ready to begin testing the meters.

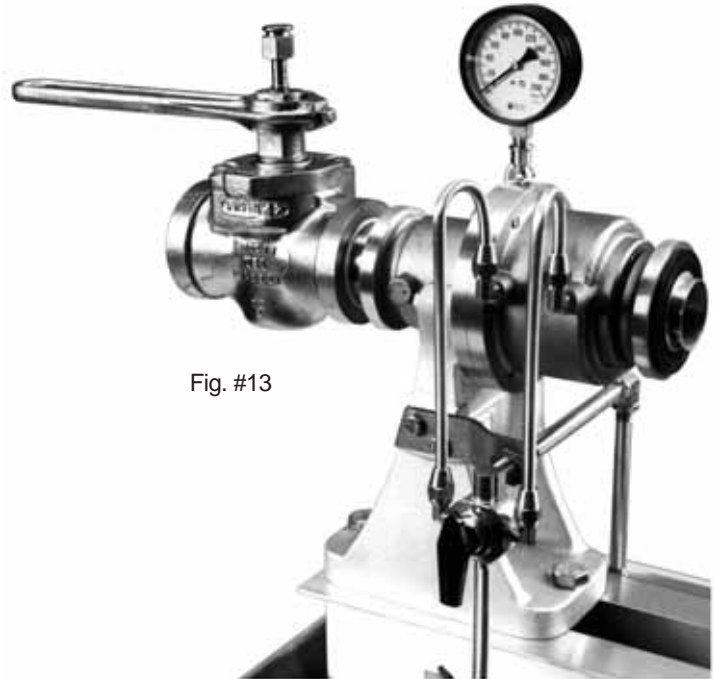

Fig. #13

The Four-Way Hydraulic Clamping Valve on an Akron Test Bench.

---

## The Akron Tester Clamp For 3", 4" and 6" Meters

The Akron Test Bench can be adapted for testing 3", 4" and 6" meters by means of a tester clamp shown in the picture at right (Catalog No. TC-A). The two ells, connected by a solid bar, clamp into one of the bench units, the same as a 2" meter. Two six-foot lengths of 2" diameter hose connect the ells to meter flanges of 3", 4" or 6" sizes, which are interchangeable and bolt to meters for testing.

Even with moderate pressure available, the rate of flow is well beyond the 100 gpm recommended for minimum rate testing of many types of 6" meters. Note: Flow tests may not be accurate due to specific meter application requirements which may require straight runs before and after the meter.

The large meter can be placed on the floor, or in a pan, in front of the Akron Test Bench. The bench with tester clamp provides convenience in connecting the meter for test, valves for control and adjustment of test flows, and the Double Range Testerate Indicator for accurate indication of test flow rates.

Each Akron Tester Clamp includes parts shown in the picture at right, plus flanges for 3", 4" and 6" meters.



# Installing the Double Range Testerate Indicator

## Akron Test Benches

### Unpacking

1. The Model KTI Testerate Indicator is packed loosely assembled to the Double Range Indicator (Catalog No. KTI-DR) to prevent shipping damage. After unpacking and inspecting for damage, remove the flexible plastic tubing from inside the KTI Testerate Indicator. This tubing secures the rotor during shipment.

### Installing

1. Rubber gaskets are included that should be placed between the indicator and the copper piping. Use two wrenches to assemble the KTI to the double range brass assembly. Place one wrench on the coupling attached to the KTI and use the other wrench on the piping swivel nut. Snug both ends being careful to avoid twisting the KTI frame.
2. Assemble the Double Range Testerate Indicator to the bench. **Be sure to install the Double Range Testerate Indicator with the 2" ball valve positioned AT THE TOP.**

Double Range  
Testerate Indicator  
Catalog No. KTI-DR

**NOTE:** The Double Range Testerate Indicator is shown in the upright position as it is to be assembled to the test bench.

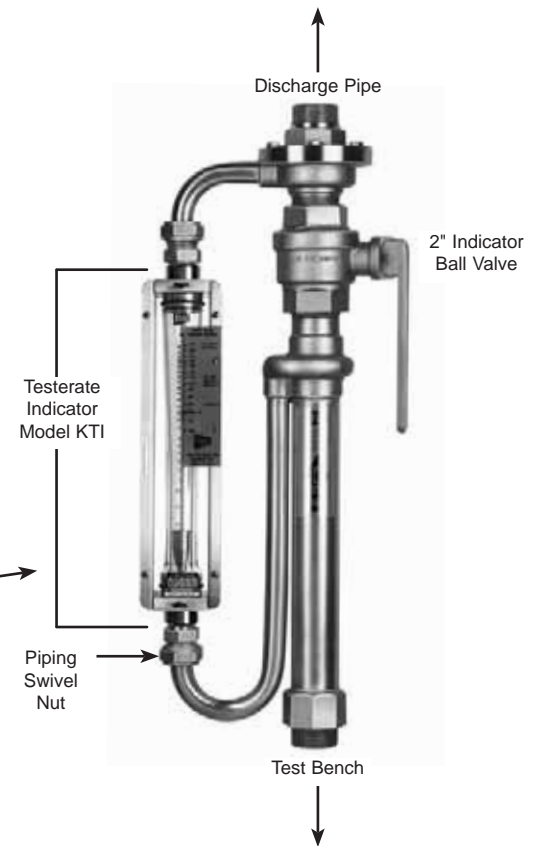

## Important Information for Proper Operation of the Double Range Testerate Indicator

1. When operating the Double Range Testerate Indicator on low flows, make sure the valve is closed. This diverts all of the water through the indicator. Read the flow rate directly off the Testerate Indicator calibrations (glass gauge tube).
2. When using the indicator for high flows, make sure the ball valve is open. Read the flow rate from the brass double range scale (brass plate).

**CAUTION:** The Testerate Indicator is a delicate instrument and is easily damaged by abuse or improper use. One of the common ways of damaging the Testerate Indicator is to have the blow-off valve closed when the inlet valve is opened. This compresses the air in the meters. If the outlet valve is then opened abruptly, the compressed air rushes through the Testerate Indicator causing violent movement of the rotor inside the glass gauge tube. This could cause damage to the indicator.

When operating the test bench, make sure the blow-off valve is open while opening the inlet valve. Do not close the blow-off valve until the system has purged itself of air. When testing begins, open the outlet valve slowly as some air will remain between the outlet valve and Testerate Indicator.

To drain the Double Range Indicator after use: 1) Close the 2" Indicator valve. 2) Open the bench outlet flow control valve. 3) Open the bench blow-off valve.

# Miscellaneous Parts and Electric Flow Control Unit Parts

## METER IDLERS

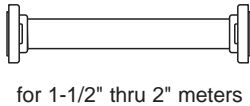
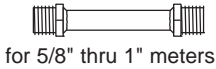

CATALOG NUMBER	DESCRIPTION	APPROX. WT. LBS.	STD. PKG. QTY.
IDLER-1	Replaces 5/8" Meter	.6	40
IDLER-2	Replaces 5/8"x3/4" Meter	0.9	25
IDLER-2P	Replaces 5/8"x3/4" Meter (Plastic)	-	-
IDLER-3	Replaces 3/4" Meter	0.9	18
IDLER-3P	Replaces 3/4" Meter (Plastic)	-	-
IDLER-4	Replaces 1" Meter	1.8	10
IDLER-4P	Replaces 1" Meter (Plastic)	-	-
IDLER-6	Replaces 1-1/2" Flanged Meter	5.8	4
IDLER-7	Replaces 2" Flanged Meter	10.8	3

## Miscellaneous Tester and Tank Parts

CATALOG NUMBER	DESCRIPTION
9603	Gage Glass for Standard Calibrated Tank (4 ft.)
9605	1" Drain Valve for 1-F or 10-G Tank
9606	1-1/2" Drain Valve for 20-GF or 10-FG Tank
9607	2" Drain Valve for 100-GF Tank
9608	3" Drain Valve
9616	Tube and Rotor Assembly for KTI Testerate Indicator
9617	Meter Vise Inlet Plug with Ring
9618	Meter Vise Outlet Plug
9619	Set of 8 Brass Rings for Standard Tester Clamp

## Electronic Control Unit Parts

CATALOG NUMBER	DESCRIPTION
9609	Electric Valve only with Solenoid, Less Wire
9610	3/8" Strainer with Union
9610-S	Wire Mesh Strainer only
9621	Electrode with Tube and Clamp at standard 21-1/4" length. For custom lengths, use 9621-xx
9621-xx	For custom length electrodes, provide the distance in inches from top of tank to water test level. Specify "electrodes to be ___ inches long." For each additional inch, add to price where xx is the total inches from top of tank to water test level.
9622	Flow Control Needle Valve for Electric Control Unit Bypass
9623	Electric Control Box <b>with</b> External Wires
9628	Banana Plug only (each)

Caution: Wire replacement requires a qualified electrician.

## Meter Shop Accessories

CATALOG NUMBER	DESCRIPTION
9541	Meter Repair Bench with Vise and Sink (approx. wt. lbs. 540.0)
9547	Meter Vise

CONTACT FACTORY FOR QUOTATION ON ANY OTHER PARTS WHICH ARE NOT LISTED

## Electric Flow Control Unit Service and Maintenance

1. Periodically check electrode settings by glancing at the water level in the tank at the finish of the test. Adjust the electrodes if necessary.
2. Keep the lower ends of the electrodes clean and free from corrosion. An accumulation of scale can cause erratic or late valve closure. Clean the electrode and the copper tubing with steel wool. Readjust electrodes after cleaning.
3. Periodically check and clean the strainer that is located in the lower pipe union on the bypass.
4. Periodically inspect and clean the solenoid valve. Instructions are shipped with the valve and also accompany this manual.
5. Component repair parts are available for the Electric Flow Control Unit. See diagrams at the bottom of this page.

**DANGER: An electric shock or burn hazard exists in the transformer relay box. Service must be performed by qualified personnel only after disconnecting the power source.**

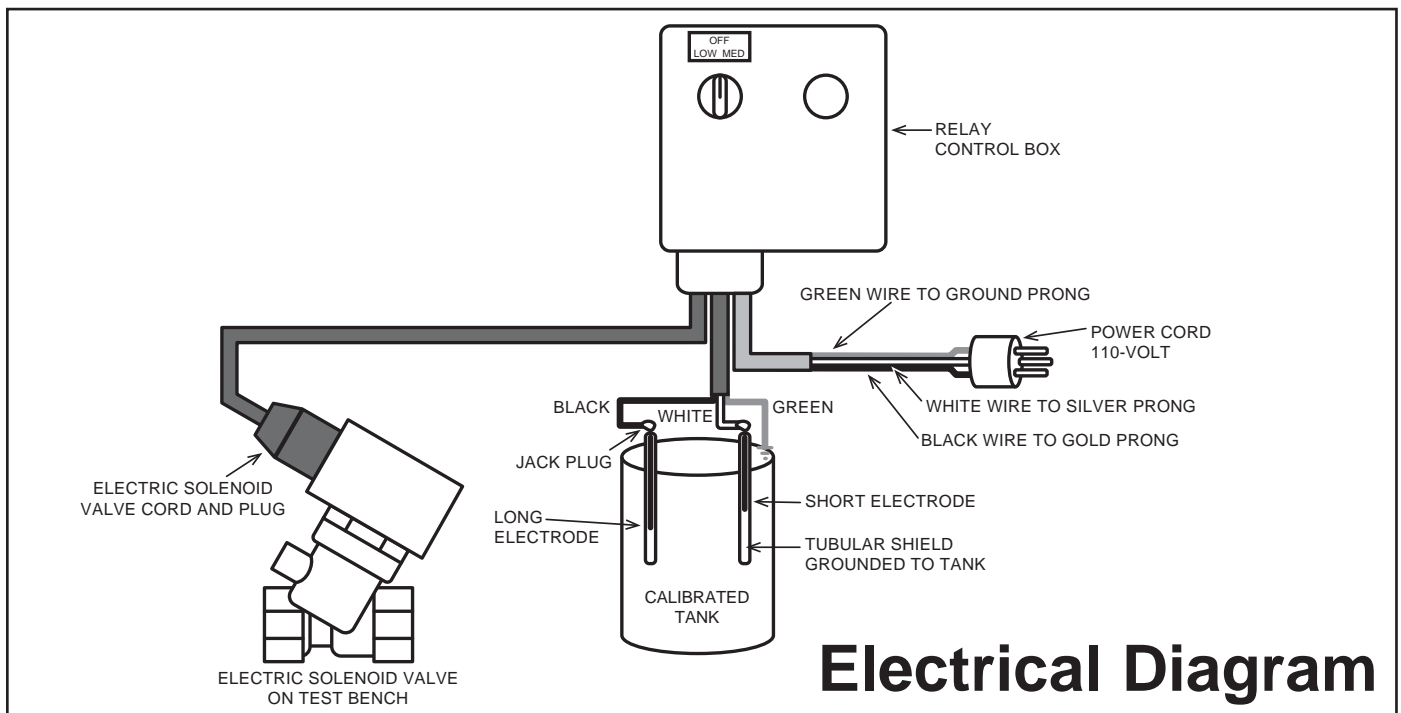
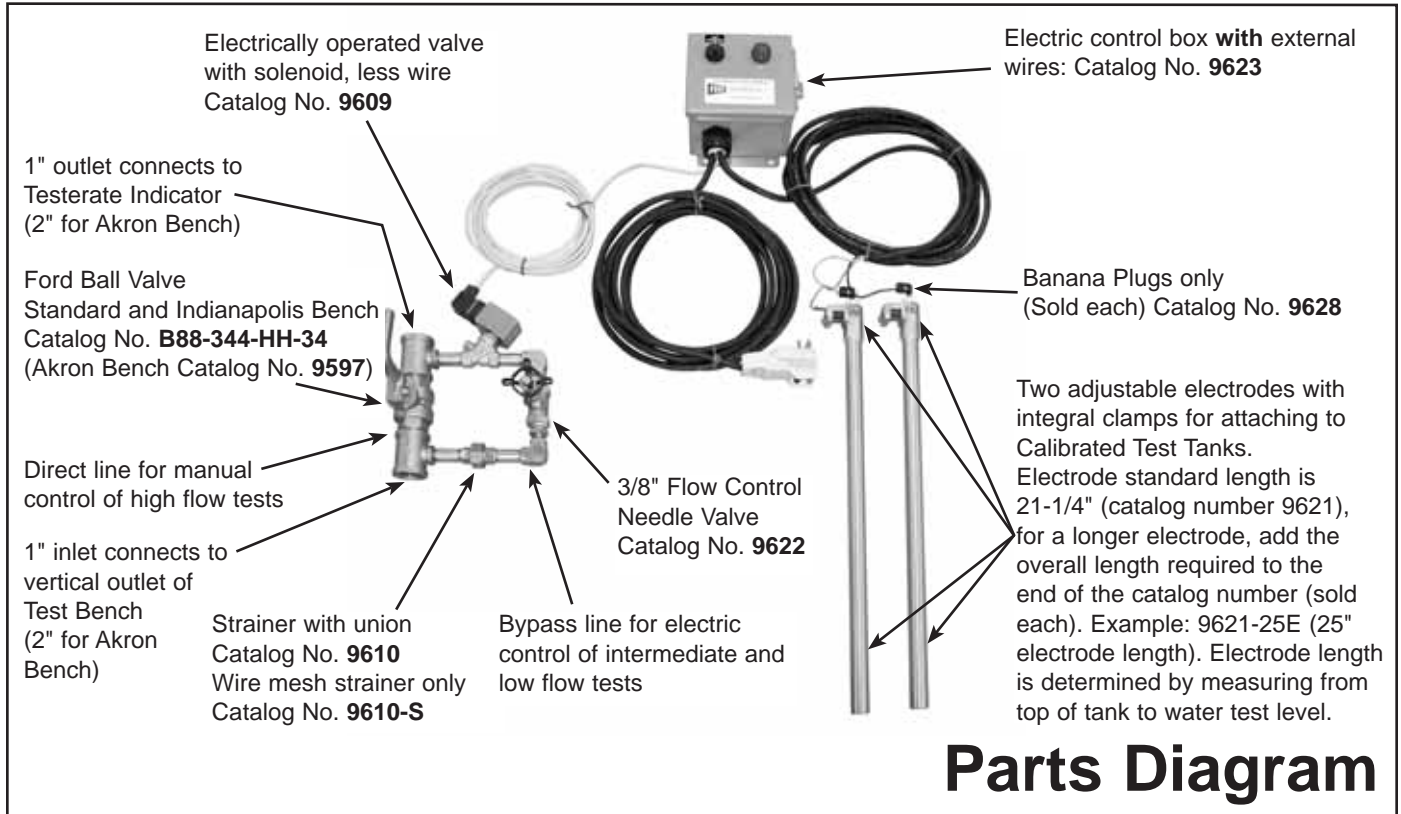

# Installation and Operation Instructions

## Electric Flow Control Equipment

Automatic shut-off for water flow when testing meters permits the operator to start the test and then do other work until the test is completed. High-flow tests are of short duration and manual flow shut-off by the operator is recommended. Low and medium tests are usually run using a small tank; the Electric Control Unit (or optionally the Ford Auto-Stop) is ideal for these time-consuming tests. Low and medium flows are run through the bypass with the flow regulated by the flow control valve and stopped at the proper time by the electrically operated valve. When the water in the tank reaches the pre-set volume level, it makes contact with an electrode. This completes a circuit which closes the electrically controlled valve.

### Installation of Unit

1. The electrically operated valve should be installed in a bypass around the manually operated valve at the outlet of the test bench. A 3/8" pipe line (to include the 3/8" electric valve, strainer, and a compression-type flow control valve) is installed to bypass the manually controlled valve normally used for high-flow tests at the outlet of the test bench.
2. Clamp both electrodes to the top edge of the calibrated tank. Attach the transformer-relay box in a dry location firmly to the wall or other support, using the four mounting holes.
3. Plug the jacks into the top of the electrodes and attach the green ground wire to the ground screw at the top of either electrode mounting clamp.
4. Plug the power cord on the transformer-relay box into a 110-volt AC outlet. **DANGER: Due to water being splashed in and around a meter test bench, an outlet equipped with a ground fault circuit interrupter is necessary in order to protect personnel from fatal electrical shock. Installation and maintenance requires a qualified electrician.**

### Adjustments

#### Low Flow

1. Fill calibration tank to within a few inches of the bottom of the short electrode.
2. Activate the electronic controls by positioning the multi-function switch to "LOW."
3. The (short) electrode with the white wire jack is for the control of low flows.
4. Route water through the electrical valve bypass system by closing the main discharge valve. Open the flow control valve to allow approximately a quarter gallon-per-minute flow as indicated on the Ford Testerate Indicator.
5. Adjust position of the low-flow (short) electrode up or down so that the water stops flowing when the tank is filled to the desired calibration point. Adjusting is accomplished by loosening the set screw at the top of the electrode.

#### Medium Flow

1. Fill calibration tank to within a few inches of the bottom of the long electrode.
2. Activate the electronic controls by positioning the multi-function switch to "MED."
3. The (long) electrode with the black wire jack is for the control of medium flows. Disconnect the white wire jack from the electrode during adjustment.
4. Route water through the electric valve bypass system by closing the main discharge valve. Open the flow control valve to allow approximately two GPM flow as indicated on the Ford Testerate Indicator.
5. Adjust the position of the medium-flow (long) electrode up or down so that the water stops flowing and/or draining when the tank is filled to the exact calibration point. The medium flow (long) electrode will need to be set slightly lower than the low-flow (short) electrode. This is because the amount of water that drains into the tank after the electronic valve closes during the medium-flow test is greater than after slow flows.
6. Reconnect the white wire jack to the low-flow (short) electrode.

#### High or Full Flow

1. Turn off the power switch on the control box.
2. Close the flow control valve in the bypass.
3. The test bench is now ready for high-flow testing. Adjust flow to the desired rate with the lever handle discharge valve.
4. The larger tank is generally used for this test.

# The Ford Test Bench Auto-Stop

Designed to automate testing operations and provide a wide range of flow tests on water meter test benches, Ford introduces the Auto-Stop. Performing up to three user-adjusted flow rate tests, the Auto-Stop utilizes the joystick control to stop and start tests as well as drain the test tank. With sensors on each tank, the test is terminated automatically once the water level reaches pre-set tank levels.

## Features:

- Designed to work with the Standard, Indianapolis, and Akron Test Bench
- Easily adaptable to any commercial test bench
- Single joystick control
- Three user-adjustable (pre-set) flow rates
- An external sensor monitors tank to stop test at pre-set levels
- No calibration required
- Overflow protection
- Adjustable valve closure rate for consistent tank level as well as water hammer prevention

To order a complete unit, select the ASCB (Auto-Stop Control Box) and one outlet valve package from the table below. To include an optional drain valve package, select the DVPK (Drain Valve Pilot Kit) and at least one drain valve package (Auto-Stop can accommodate up to two drain valve packages).



ITEM	PART NUMBER	COMPONENT NUMBER	DESCRIPTION
<b>Auto-Stop Control Box</b>	<b>ASCB</b>		Auto-Stop Control Box
<b>Outlet Valve Package</b> (one required with ASCB)		<b>OVPKG-4</b>	Outlet Valve Package for 1" NPT Outlets (complete outlet valve package for Standard and Indianapolis Benches)
		<b>OVPKG-7</b>	Outlet Valve Package for 2" NPT Outlets (complete outlet valve package for Akron Benches)

### Optional Drain Valve Pilot Kit and Drain Valve Package Selection

<b>Drain Valve Pilot Kit Drain Package</b> (select DVPK and one or two Drain Valve Package(s))	<b>DVPK</b>		To automate tank drain, select the DVPK (Drain Valve Pilot Kit) and one or two of the Drain Valve Packages below
		<b>DVPKG-4</b>	Drain Valve Package for 1" NPT (drain valve for small tanks)
		<b>DVPKG-7</b>	Drain Valve Package for 2" NPT (drain valve for mid-size tanks)
		<b>DVPKG-9</b>	Drain Valve Package for 3" NPT (drain valve for large tanks)

**Note:** Special sized outlets available upon request. Contact factory for details.

**Note:** A small compressor (not included) capable of 90 to 100 psi is required to operate the valves on the Auto-Stop.

# Test Bench Parts

## Parts for Standard Test Benches

CATALOG NUMBER	DESCRIPTION	ILLUSTRATION CODE
9552	1" Inlet Ball Valve	
9553	3/4x1" Outlet Ball Valve	
KTI	KTI Testerate Indicator	
9557	18" Swinging Discharge Pipe (standard length)	
9558	24" Swinging Discharge Pipe	
9560	Pressure Gage only, 0-200 psi (1400 KPA)	
9561	Pressure Gage with Nipple and Petcock	
9562-S-A	Blow-off Valve and Discharge Tube for Standard or Akron Bench	
9563-LR	Inlet Piece with Expansion Connection / left to right flow	
9563-RL	Inlet Piece with Expansion Connection / right to left flow	
9564-LR	90° Outlet Piece with sides tapped for blow-off valve and pressure gage / left to right flow	
9564-RL	90° Outlet Piece with sides tapped for blow-off valve and pressure gage / right to left flow	
9565-LR	Intermediate Piece with Expansion Connection and Bleeder Valve Assembly / left to right flow	
9565-RL	Intermediate Piece with Expansion Connection and Bleeder Valve Assembly / right to left flow	
9566-S	Bleeder Valve Assembly with Screw, O-ring & Drain Tube (for Standard Test Bench)	<b>G</b>
9567	Bleeder Valve Screw with O-ring	<b>H</b>
9568-67	Bleeder Valve Body with Screw and O-ring	<b>H, I</b>
ORING-650012-EP	O-ring for Bleeder Valve Screw	
9568	Bleeder Valve Body only (with Plastic Seat)	<b>I</b>
9569	Drain Tube Only for Bleeder Valve (for Standard and Indianapolis Test Benches)	<b>J</b>
9570	Expansion Connection Barrel Piece only	<b>A</b>
9571	Expansion Connection Handwheel only	<b>B</b>
9572	Beveled Gland Ring	<b>C</b>
GT-62	Beveled Rubber Expansion Connection Gasket (replaces beveled leather gasket)	<b>D</b>
GT-166	Rubber Gasket for 5/8" Meters	
GT-118	Rubber Gasket for 5/8"x3/4" or 3/4" Meters (priced from Section E)	
GT-124	Rubber Gasket for 1" Meters (priced from Section H)	
9578	Tester Yoke only	
9579	Set of adapters for 5/8", 5/8"x3/4" & 3/4" Meters (per tester unit)	
9580	5/8" Screw-in Adapter for Standard Test Bench	<b>E</b>
9581	5/8" Slide Adapter for Standard Test Bench	<b>F</b>
9582	5/8"x3/4" Screw-in Adapter for Standard Test Bench	<b>E</b>
9583	5/8"x3/4" and 3/4" Slide Adapter for Standard Test Bench	<b>F</b>
9584	3/4" Screw-in Adapter for Standard Test Bench	<b>E</b>
9586	Set O-ring Gaskets for KTI Standard Testerate Indicator	
9731	Nylon Seat for Bleeder Valve Assembly	

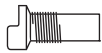

**A**  
Barrel

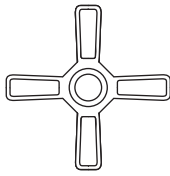

**B**  
Hand Wheel



**C**  
Gland Ring



**D**  
Gasket

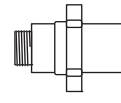

**E**  
Screw-in Adapter



**F**  
Slide Adapter

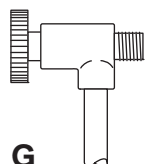

**G**  
Bleeder Valve Assembly

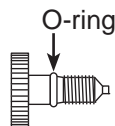

**H**  
Bleeder Valve Screw

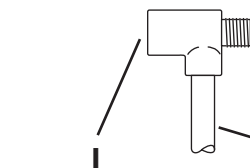

**I**  
Bleeder Valve Body Only

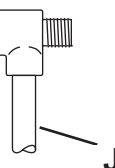

**J**  
Bleeder Valve Drain Tube



# Test Bench Parts

## Parts for Indianapolis Test Benches

The following parts are the same as on Standard Benches: 1" Inlet and Outlet Valves, Testerate Indicator and parts, Swinging Discharge Pipe, Pressure Gauge, Bleeder Valve Bodies, Blow-off Valve, Rubber Gaskets, Pans and Legs.

CATALOG NUMBER	DESCRIPTION	Illustration Code
9562-I	Blow-Off Valve and Discharge Tube for Indianapolis Bench	
9566-I	Bleeder Valve Assembly with Screw, O-ring & Drain Tube (for Indianapolis Test Bench)	
ORING-650012-EP	O-ring for Bleeder Valve Screw	
9569	Drain Tube only for Bleeder Valve (for Standard and Indianapolis Test Benches)	
9588	Short Dolly Assembly	
9592-1-LR	Indpls. Clamping Cylinder, less four-way valve and piping, for 5/8" Bench, left to right flow	
9592-1-RL	Indpls. Clamping Cylinder, less four-way valve and piping, for 5/8" Bench, right to left flow	
9592-2-LR	Indpls. Clamping Cylinder, less four-way valve and piping for 5/8"x3/4" and 3/4" Bench, left to right flow	
9592-2-RL	Indpls. Clamping Cylinder, less four-way valve and piping for 5/8"x3/4" and 3/4" Bench, right to left flow	
9592-4-LR	Indpls. Clamping Cylinder, less four-way valve and piping for 1" Bench, left to right flow	
9592-4-RL	Indpls. Clamping Cylinder, less four-way valve and piping for 1" Bench, right to left flow	
9710	Set of O-rings for Indianapolis Clamping Cylinder	
9593	Four-Way Control Valve with Handle for Hydraulic Cylinder, less piping	
9594-I	Four-Way Control Valve with Handle for Hydraulic Cylinder with piping for Indianapolis Bench	
9726	5/8" Split Ring Adapter for outlet end	
9711	5/8" Split Ring Adapter for 1" Indpls.	A
9712	5/8"x3/4" & 3/4" Split Ring Adapter for 1" Indpls.	B

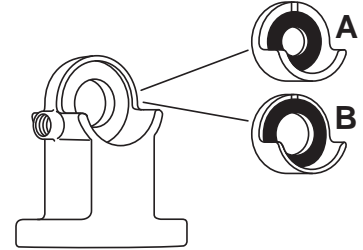

## Parts for Akron Test Benches

CATALOG NUMBER	DESCRIPTION
9562-S-A	Blow-Off Valve and Discharge Tube for Standard or Akron Bench
9566-A	Bleeder Valve Assembly with Screw, O-ring and Drain Tube for Akron Bench
ORING-650012-EP	O-ring for Bleeder Valve Screw
9569-A	Drain Tube Only for Akron Bench Bleeder Valve
9555	Box Stick Lubricant for 2" Nordstrom® Valve
9597	2" Nordstrom® Inlet Valve or Outlet Flow Control Valve
9598-LR	Inlet Clamping Cylinder, less pressure gage, four-way control valve and piping, for left to right flow
9598-RL	Inlet Clamping Cylinder, less pressure gage, four-way control valve and piping, for right to left flow
9599-LR	Intermediate Clamping Cylinder, less bleeder valve, four-way control valve and piping, for left to right flow
9599-RL	Intermediate Clamping Cylinder, less bleeder valve, four-way control valve and piping, for right to left flow
9600	2" Idler (for 'S' Akron Test Benches)
9601	2" Idler (for 'L' Akron Test Benches)
9602	Set O-rings for Akron Clamping Cylinder
9595	2" Swivel Union only for Discharge Pipe
SDP-7	2" Swing Discharge Pipe 24" reach (complete with swivel union)
9593	Four-way Control Valve for Hydraulic Cylinder, less piping
9594-A	Four-way Control Valve for Hydraulic Cylinder with piping for Akron Bench
KTI-DR	Double Range Testerate Indicator (approx. wt. lbs. - 51.0)
9620	2" Ball Valve for KTI-DR
TC-A	Tester Clamp for Akron Bench (approx. wt. lbs. - 135.0)

# Meter Adapter Requirements For the Akron Test Bench

## Meter Adapters for Akron Test Bench

CATALOG NUMBER	DESCRIPTION	APPROX. WT. LBS.
HT-30	Centering Adapter for 2" flanged meter	.3
HT-13	Adapter for 2" tapped meter	1.3
HT-15	Adapter for 1-1/2" flanged meter*	1.3
HT-32	Centering adapter for 1-1/2" tapped meter - used on nose of HT-15	.1
HT-17	Adapter for 1-1/4" flanged meter*	1.6
HT-15A	Adapter for 1-1/4" tapped meter*	1.8
HT-36	Adapter for 1-1/4" or 1x1-1/4" meter with male threads	1.3
HT-14	Adapter for 1" meter*	1.8
HT-10	Slide Saddle Holder. Used for 5/8" & 5/8"x3/4" meters to test two in each unit. Holder rests on aluminum channels	6.3
HT-34	Slide Saddle for 5/8" meters. Fits into HT-10*	1.3
HT-34A	Slide Saddle for 5/8"x3/4" and 3/4" meters. Fits into HT-10*	1.2
HT-12	Adapter for 5/8" meters*	.4
HT-12A	Adapter for 5/8"x3/4" and 3/4" meters*	1.3
9726	Adapter for 5/8" meters. Fits into HT-12A and HT-34A*	.1
HT-16	Adds 3-3/4" extra length. Used if piston travel is insufficient for clamping*	3.2
HT-31	Adds 1/2" extra length. Used if piston travel is insufficient for clamping*	.8







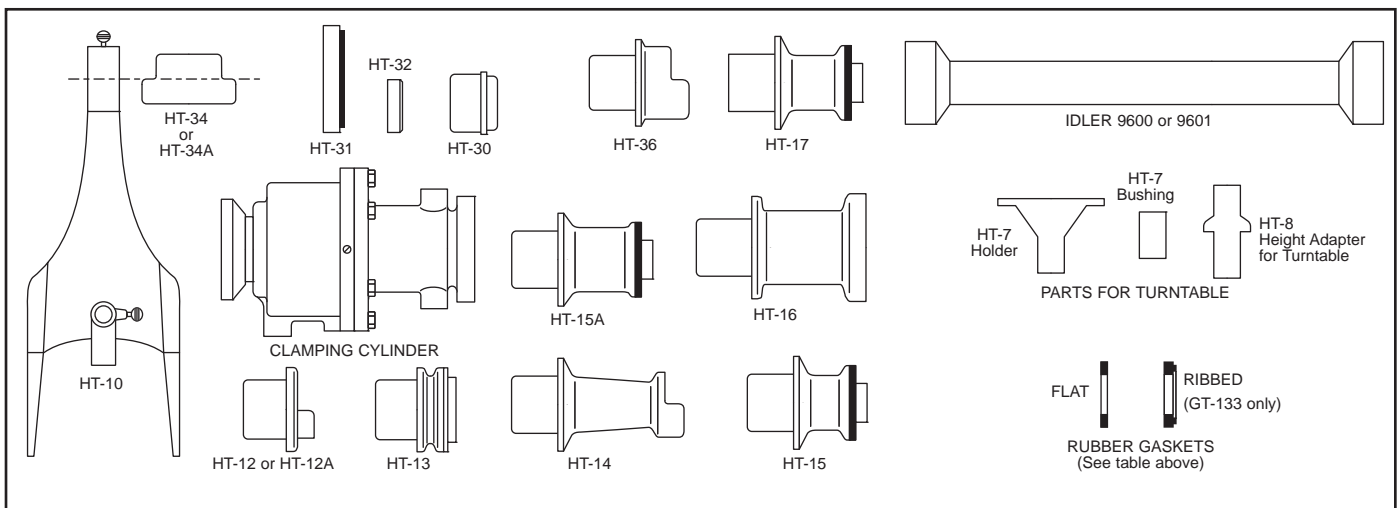













































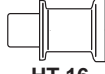











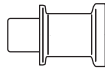



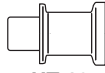

\*Gaskets included for meter end(s) of adapters, spacers and slide saddles.

## Gaskets for Akron Meter Adapters

CATALOG NUMBER	DESCRIPTION	DIMENSIONS
GT-133	Rubber Gasket for HT-16 & for clamping cylinder	2-1/8" x 3-1/4" x 3/8"
GT-134	Rubber Gasket for HT-13	2-3/16" x 2-7/8" x 1/4"
GT-139	Rubber Gasket for HT-17	1-7/32" x 2-1/8" x 5/16"
GT-129	Rubber Gasket for HT-15 and HT-15A	1-15/32" x 2-3/8" x 5/16"
GT-124	Rubber Gasket for HT-14	1-1/16" x 1-21/32" x 1/8"
GT-118	Rubber Gasket for HT-12A and HT-34A	13/16" x 1-11/32" x 1/8"
GT-166	Rubber Gasket for HT-12 and HT-34	11/16" x 1-7/64" x 1/8"
GT-132	Rubber Gasket for HT-31	2" x 3-1/4" x 1/8"
GT-128	Rubber Gasket for HT-36	1-1/4" x 1-29/32" x 1/8"

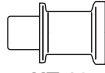

# Meter Adapter Requirements For the Akron Test Bench

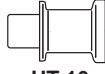
METER		For "S" Style, 17"					Add HT-16 For "L" Style, 21"		
SIZE	LENGTH								
5/8"	7-1/2"	 HT-12		 *HT-34		 HT-12	 HT-16		
5/8"x3/4"	7-1/2"	 HT-12A		 *HT-34A		 HT-12A	 HT-16		
**3/4"	9"	 HT-16	 HT-12A		 HT-12A	 HT-16	N/A		
***3/4"	9"	 HT-31	 HT-12A		 *HT-34A		 HT-12A	 HT-31	 HT-16
1"	10-3/4"	 HT-14			 HT-14		 HT-16		
1"x1-1/4"	10-3/4"	 HT-36		 HT-36	 HT-16	 HT-16			
1-1/4" male	11-1/2"	 HT-36		 HT-36	 HT-16	 HT-16			
1-1/4" tapped	11-1/4"	 HT-15A		 HT-15A	 HT-16				
1-1/4" flange	12"	 HT-17		 HT-17	 HT-16				
1-1/2" male	12-5/16"	 HT-15A		 HT-15A	 HT-16				
1-1/2" tapped	12-5/8"	OPTIONAL  HT-15		OPTIONAL  HT-15A	 HT-16				
1-1/2" flange	13"	 HT-15		 HT-15	 HT-16				
2" flange (turbine)	10"	 HT-16		 HT-16	 HT-16				
2" tapped	15-1/4"	 HT-13		 HT-13	 HT-16				
2" flange	17"	 HT-30		 HT-30	 HT-16				

\*HT-34 and HT-34A require HT-10. See page 26.

\*\*For "S" Style Akron Test Benches only.

\*\*\*For "L" Style Akron Test Benches only.

**NOTE:** The Akron Test Bench is made in "S" Style for 17" meters and "L" Style for 21" meters.

# General Test Bench Maintenance

## Test Bench Maintenance

The substantial steel pans of all meter test benches are heavily galvanized but can be painted to produce color harmony if desired. Iron yoke pieces and non-moving brass parts can also be painted on the outside.

Replace all test bench gaskets when worn. The rubber gaskets of Indianapolis and Akron Benches, as well as the O-ring in the clamping cylinders, should be renewed when necessary. See page 31 for replacing clamping cylinder O-rings.

Occasionally oil the threads of the barrel pieces and the handwheels of Standard Benches. A little grease or oil on the faces of the handwheel where it contacts the yoke shelf and packing gland makes for easier operation. Oil can also be applied to the pistons of the clamping cylinders of Indianapolis and Akron Benches, improving the action and prolonging the life of O-rings and metal parts. Lubrication of the spring fork pivots of Indianapolis Benches and the pedestal screws of Akron Benches makes for easier and better operation. Instructions for removal and cleaning of the Testerate Indicator gauge tube are on page 29 and 30.

## Calibrated Tank Maintenance

If placed on any floor or base which is not substantial and is likely to settle, tanks should be occasionally replumbed. Take precaution against denting the tanks. Dents could cause inaccurate test results.

With reasonable care, calibrated tanks should remain accurate indefinitely. Smaller sizes are heavily galvanized and larger sizes can be entered for painting when necessary. Drain tanks when not in use. Clean the inside of glass tubes with a lime-dissolving cleanser and a small swab on a wire. If a gauge glass becomes broken, a new tube can be installed quickly and easily.

**NOTE:** Tanks are calibrated with O.E.M. Drain Valves. Alternate valve replacement may cause inaccurate test results.

## Valve Maintenance

Test Bench inlets and outlets have easy-operating valves. Ford Ball Valves are used wherever possible and will provide many years of maintenance-free service. Lubrication instructions for the Nordstrom® Akron flow control valve are on page 32. The four-way control valves for clamping cylinders on Indianapolis and Akron Benches are maintenance-free; replace the valves if they leak or fail. **NOTE:** A four-way control valve thought to be leaking is usually the clamping cylinder O-rings, which require replacement (see page 31), and not the four-way control valve.

# Removal and Cleaning of the Gauge Tube on Testerate Indicators

If the glass tube becomes dirty from lime, grease, rust, etc., it can easily be cleaned by removing it from the frame.

1. Remove the swing discharge pipe/swivel union and the four buttonhead capscrews from the top of the Indicator assembly.
2. Pull the brass fitting from the top of the Testerate Indicator frame. The guide rod and rotor will usually remain attached to the brass fitting.
3. Pull the glass tube and rotor assembly from the top of the frame and off the bottom brass fitting. Remove, clean and reinstall the glass tube with extreme caution; the slightest bump can chip or break the glass.
4. Clean the glass tubing with a soft bristled bottle brush to prevent scratching the inside surface. A mild detergent, such as soap and vinegar, is an acceptable cleaning solution.
5. After cleaning, reassemble in the reverse order. Adding a little grease to the O-rings is recommended.

Replacement tube and rotor assemblies are available for current production models. With reasonable care the Testerate Indicator will remain accurate and in useful condition for many years. For further information, or if you have any difficulty in installing or using the Testerate Indicator, please contact The Ford Meter Box Company.

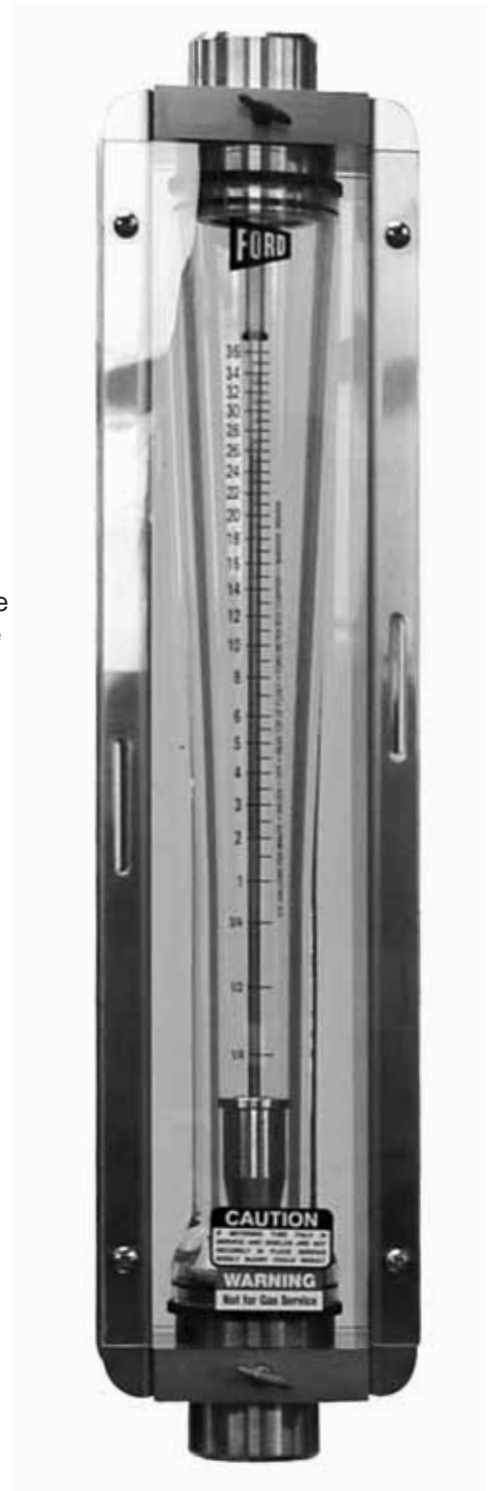

The Testerate Indicator has a length of 17-5/8". Both ends are tapped 1" I.P. thread.

# Removal and Cleaning of the Gauge Tube on Testerate Indicators

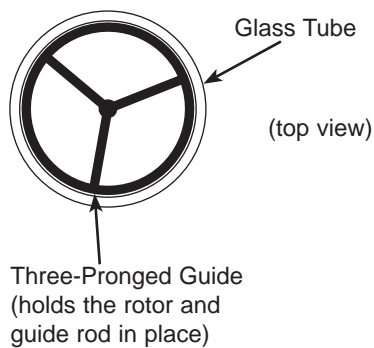
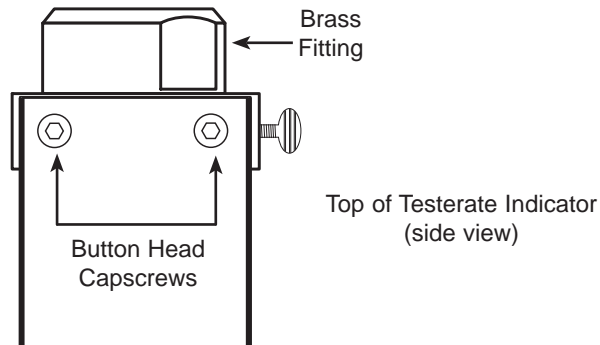
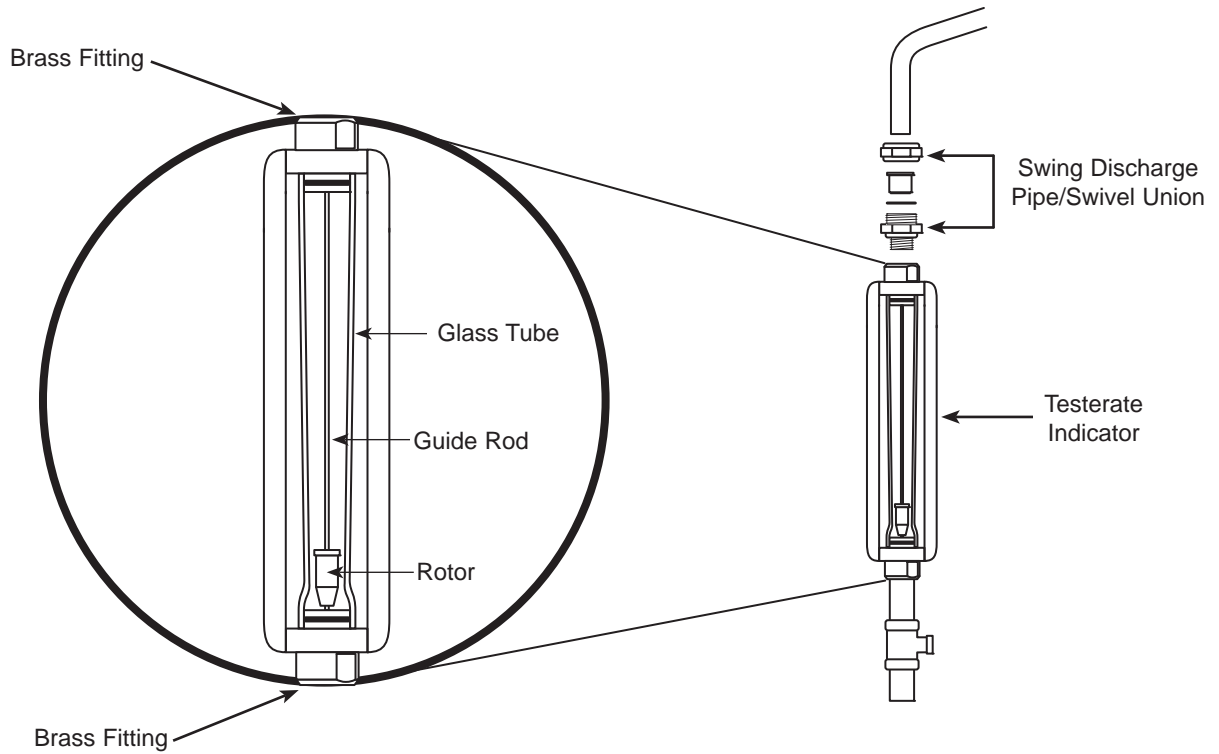

# Instructions for Replacing O-rings In Akron Test Bench Cylinders / Part No. 9602

There are four O-rings and one washer which can be replaced to ensure a proper seal. The cylinder must be completely taken apart in order to replace all four O-rings.

The end piece ring (HT-6) must be removed. Cylinders purchased prior to 1990 require careful use of a soft-headed hammer to dislodge the end ring (HT-6) from the piston. On cylinders purchased after 1990, the HT-6 will easily pull off by hand. Remove the screw and washer from the oil hole. Remove the brass hex head bolts and separate the two halves (HT-4 and HT-3), then remove the piston.

Clean the cylinder and piston shaft with fine steel wool for smooth operation. Grease the replacement O-rings with a light-weight grease. Replace the O-ring on the piston (B), the O-ring in each of the halves (A) and the O-ring where the two halves meet (C). Cylinders purchased after 1990 will also have an O-ring on the HT-6 end piece ring (D).

To reassemble the cylinder, place the piston back into the HT-3 and HT-4. Replace the brass bolts. If purchased prior to 1990, the HT-6 must carefully and evenly be tapped onto the end of the piston. A block of wood is often helpful. The HT-6 will easily slide onto the end of the piston on cylinders purchased after 1990. A new washer for the oil hole is also included in the O-ring replacement kit. Replace the washer and put the oil screw back into the HT-4. This completes the O-ring replacement of the Akron Test Bench cylinder.

Periodic oiling of the cylinder with vegetable oil will prolong the life of the O-rings.

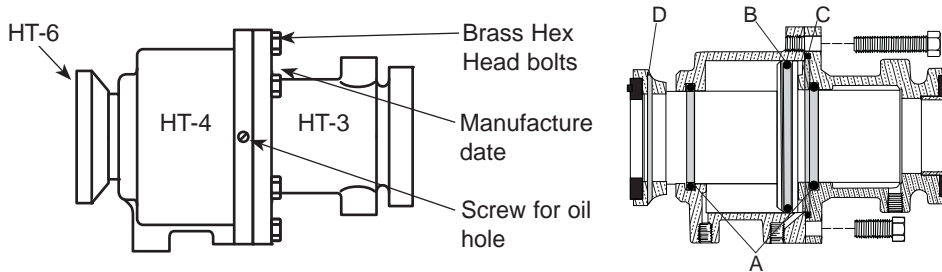

O-ring	O-ring Inside Diameter
A (2 Provided)	2.475"
B	3.6"
C	4.109"
D	2.359"

*O-ring D is only available on cylinders purchased after 1990.*

# Instructions for Replacing O-rings In Indianapolis Test Bench Cylinders / Part No. 9710

There are four O-rings and one washer which have to be replaced to ensure a proper seal. The cylinder must be completely taken apart in order to replace all four O-rings.

Remove the screw and washer from the oil hole. The two cylinder halves (TM-1 and TM-2) have to be separated by removing the brass hex bolts. Now separate the two halves and remove the piston.

Clean the cylinder and piston shaft with fine steel wool for smooth operation. Grease the replacement O-rings with a light-weight grease. Replace the O-ring on the piston (B), the O-ring in each of the halves (A) and the O-ring where the two halves meet (C).

To assemble the cylinder, place the piston back into the TM-2 and TM-1 very carefully not to cut the O-rings. Replace the brass bolts. A new washer for the oil hole is also included in the O-ring replacement kit. Replace the washer and put the oil screw back into the TM-2.

Periodic oiling of the cylinder with vegetable oil will prolong the life of the O-rings.

O-ring	O-ring Inside Diameter
A (Two Provided)	1.359"
B	2.1"
C	2.734"

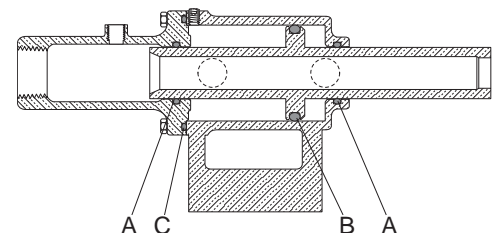
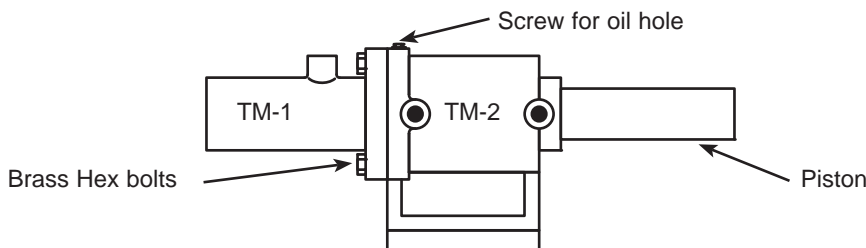

# The NORDSTROM® Valve

This is a copy of the tag that should be found on the outlet flow control valve of a Ford test bench shipped with a Nordstrom® valve. Please refer to these lubrication instructions when operating a bench fitted with a Nordstrom® valve.

## Important Notice for Proper Valve Lubrication

It is very important that this Rockwell Nordstrom® valve be kept properly lubricated with the correct lubricant at all times. This valve is *shipped* lubricated. It can be kept lubricated by occasionally turning the lubricant bolt located on the valve stem one or two turns. This forces grease into the valve. **DO NOT OVER-LUBRICATE.** Turning this bolt more than two turns at one time forces an excessive amount of grease into the valve. Water flow will wash this excess grease into the Testerate Indicator requiring disassembly and cleaning.

## Replacing the Lubricant Stick

When the bolt has bottomed out, additional lubricant is required. A box of proper lubricant sticks has been furnished with this valve. To replace a lubricant stick, unscrew the lubricant bolt on the valve stem, insert the lubricant stick and replace the bolt. When the bolt makes contact with the lubricant stick, resistance to the bolt will be noticed – only turn this bolt a turn or two to avoid over-lubricating the valve. If no resistance is developed against the bolt, it means the lubricant chamber is not full or the bolt is not properly seated. If the valve is infrequently operated, the bolt should be given a turn each time before operating the valve. Additional lubricant can be ordered from the Ford Meter Box Company, Wabash, Indiana.

1. Wrench Square
2. Rockwell Fitting (combination lubricant bolt and gun fitting)
3. Sealant Check Valve (double ballcheck prevents escape of sealant)
4. Sealant Grooves (provide “sealdport” sealant system)
5. Sealant Chamber (provides plug “jacking” force)

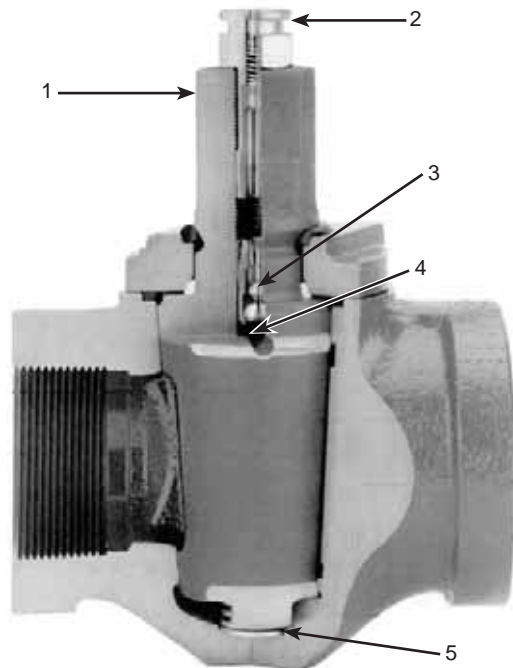





# Test Requirements for New, Rebuilt and Repaired Cold Water Meters\*

Maximum Rate (All Meters)					Intermediate Rate (All Meters)					Minimum Rate (New and Rebuilt)				
Size In.	Rate† of Flow gpm	Test Quantity††		Accuracy Limits Percent	Rate of Flow gpm	Test Quantity††		Accuracy Limits Percent	Rate of Flow gpm	Test Quantity††		Accuracy Limits Percent		
		Gal.	Cu. Ft.			Gal.	Cu. Ft.			Gal.	Cu. Ft.	New & Rebuilt Meters	Repaired Meters	
<b>DISPLACEMENT METERS (AWWA C700 AND C710)</b>														
1/2	8	100	10	98.5-101.5	2	10	1	98.5-101.5	1/4	10	1	95-101	90	
1/2x3/4	8	100	10	98.5-101.5	2	10	1	98.5-101.5	1/4	10	1	95-101	90	
5/8	15	100	10	98.5-101.5	2	10	1	98.5-101.5	1/4	10	1	95-101	90	
5/8x3/4	15	100	10	98.5-101.5	2	10	1	98.5-101.5	1/4	10	1	95-101	90	
3/4	25	100	10	98.5-101.5	3	10	1	98.5-101.5	1/2	10	1	95-101	90	
1	40	100	10	98.5-101.5	4	10	1	98.5-101.5	3/4	10	1	95-101	90	
1-1/2	50	100	10	98.5-101.5	8	100	10	98.5-101.5	1-1/2	100	10	95-101	90	
2	100	100	10	98.5-101.5	15	100	10	98.5-101.5	2	100	10	95-101	90	
<b>MULTI-JET METERS (AWWA C708)</b>														
5/8	15	100	10	98.5-101.5	1	10	1	98.5-101.5	1/4	10	1	97-103	90	
5/8x3/4	15	100	10	98.5-101.5	1	10	1	98.5-101.5	1/4	10	1	97-103	90	
3/4	25	100	10	98.5-101.5	2	10	1	98.5-101.5	1/2	10	1	97-103	90	
1	35	100	10	98.5-101.5	3	10	1	98.5-101.5	3/4	10	1	97-103	90	
1-1/2	70	100	10	98.5-101.5	5	100	10	98.5-101.5	1-1/2	100	10	97-103	90	
2	100	100	10	98.5-101.5	8	100	10	98.5-101.5	2	100	10	97-103	90	
<b>CLASS I TURBINE METERS (AWWA C701)</b>														
3/4"	30	100	10	98-102					1-1/2	10	1	98-102	-	
1	50	100	10	98-102					2	10	1	98-102	-	
1-1/2	100	200	20	98-102					3	100	10	98-102	-	
2	160	500	50	98-102					4	100	10	98-102	-	
3	350	1,000	100	98-102					6	100	10	98-102	-	
4	600	1,500	200	98-102					8	400	50	98-102	-	
6	1,250	4,000	500	98-102					15	1,000	100	98-102	-	
<b>CLASS II TURBINE METERS (AWWA C701)</b>														
1-1/2	120	500	50	98.5-101.5					4	100	10	98.5-101.5	-	
2	160	500	50	98.5-101.5					4	100	10	98.5-101.5	-	
3	350	1,000	100	98.5-101.5					8	100	10	98.5-101.5	-	
4	630	1,500	200	98.5-101.5					15	100	10	98.5-101.5	-	
6	1,400	4,000	500	98.5-101.5					30	1,000	100	98.5-101.5	-	
8	2,400	7,000	900	98.5-101.5					50	1,000	100	98.5-101.5	-	
10	3,800	10,000	1,300	98.5-101.5					75	1,000	100	98.5-101.5	-	
12	5,000	15,000	2,000	98.5-101.5					120	1,000	100	98.5-101.5	-	
16	10,000	30,000	4,000	98.5-101.5					200	1,000	100	98.5-101.5	-	
20	15,000	40,000	5,000	98.5-101.5					300	1,000	100	98.5-101.5	-	

Note 1. All tests must be made for one or more complete revolutions of the test hand, not fractions of revolutions.

Note 2. As this rate varies according to manufacturer, it should be determined for each make of meter tested. Quantity should be one or more full revolutions of test hand, but not less than three minutes running.

\* A rebuilt meter is one that has had the measuring element replaced with a factory-made new unit. A repaired meter is one that has had the old measuring element cleaned and refurbished in a utility repair shop.

† These are suggested test flows. Testing for performance of high rates of flow can be achieved by testing the meter at 25% of the meter's rating if the manufacturer's original test certificate indicates a linear curve between 25% and 100% of the rated flow range.

‡ The bypass meter should be tested in accordance with the appropriate test requirements for the type of meter used.

†† Quantity should be one or more full revolutions of the test hand but not less than three minutes running.

# Test Requirements for New, Rebuilt and Repaired Cold Water Meters\*

Maximum Rate (All Meters)					Intermediate Rate (All Meters)					Minimum Rate (New and Rebuilt)			
Size In.	Rate† of Flow gpm	Test Quantity††		Accuracy Limits Percent	Rate of Flow gpm	Test Quantity††		Accuracy Limits Percent	Rate of Flow gpm	Test Quantity††		Accuracy Limits Percent	
		Gal.	Cu. Ft.			Gal.	Cu. Ft.			Gal.	Cu. Ft.	New & Rebuilt Meters	Repaired Meters
<b>PROPELLER METERS (AWWA C704)</b>													
2	100	300	40	98-102					35	200	25	98-102	90
3	250	800	100	98-102					40	200	25	98-102	90
4	500	1,500	200	98-102					50	250	30	98-102	90
6	1,200	2,500	300	98-102					90	500	60	98-102	90
8	1,500	3,000	400	98-102					100	500	60	98-102	90
10	2,000	4,000	500	98-102					125	500	60	98-102	90
12	2,800	6,000	800	98-102					150	750	100	98-102	90
14	3,750	8,000	1,000	98-102					250	1,000	130	98-102	90
16	4,750	10,000	1,300	98-102					350	1,500	200	98-102	90
18	5,625	12,000	1,600	98-102					450	2,000	250	98-102	90
20	6,875	15,000	2,000	98-102					550	2,500	300	98-102	90
24	10,000	20,000	2,500	98-102					800	4,000	500	98-102	90
30	15,000	30,000	4,000	98-102					1,200	6,000	800	98-102	90
36	20,000	40,000	5,000	98-102					1,500	7,500	1,000	98-102	90
42	28,000	40,000	5,000	98-102					2,000	10,000	1,300	98-102	90
48	35,000	50,000	6,000	98-102					2,500	12,500	1,500	98-102	90
54	45,000	60,000	8,000	98-102					3,200	16,000	2,000	98-102	90
60	60,000	70,000	9,000	98-102					4,000	20,000	2,500	98-102	90
66	75,000	80,000	11,000	98-102					4,750	25,000	3,000	98-102	90
72	90,000	90,000	12,000	98-102					5,500	28,000	3,500	98-102	90

Maximum Rate (All Meters)						Intermediate Rate (All Meters)					Minimum Rate (New and Rebuilt)			
Size In.	Rate† of Flow gpm	Test Quantity††		Accuracy Limits Percent		Rate of Flow gpm	Test Quantity††		Accuracy Limits Percent	Rate of Flow gpm	Test Quantity††		Accuracy Limits Percent	
		Gal.	Cu. Ft.	Class 1	Class 2		Gal.	Cu. Ft.			Gal.	Cu. Ft.	New & Rebuilt Meters	Repaired Meters
<b>COMPOUND METERS (AWWA C702)‡</b>														
2	160	400	50	97-103	98.5 - 101.5				90-103			95-101	90	
3	320	1,000	100	97-103	98.5 - 101.5				90-103			95-101	90	
4	500	1,500	200	97-103	98.5 - 101.5				90-103			95-101	90	
6	1,000	3,000	400	97-103	98.5 - 101.5				90-103			95-101	90	
8	1,600	4,000	500	97-103	98.5 - 101.5				90-103			95-101	90	
10	2,300	4,000	500	97-103	98.5 - 101.5				90-103			95-101	90	
<b>FIRE-SERVICE METERS (AWWA C703)‡</b>														
3	300	700	100	97-103	98.5-101.5				Not Less Than 85			Not Less Than 95	90	
4	700	1,500	200	97-103	98.5-101.5				Not Less Than 85			Not Less Than 95	90	
6	1,600	3,000	400	97-103	98.5-101.5				Not Less Than 85			Not Less Than 95	90	
7	2,800	5,000	700	97-103	98.5-101.5				Not Less Than 85			Not Less Than 95	90	
10	4,400	9,000	1,200	97-103	98.5-101.5				Not Less Than 85			Not Less Than 95	90	

Note 1. All tests must be made for one or more complete revolutions of the test hand, not fractions of revolutions.

Note 2. As this rate varies according to manufacturer, it should be determined for each make of meter tested. Quantity should be one or more full revolutions of test hand, but not less than three minutes running.

\* A rebuilt meter is one that has had the measuring element replaced with a factory-made new unit. A repaired meter is one that has had the old measuring element cleaned and refurbished in a utility repair shop.

† These are suggested test flows. Testing for performance of high rates of flow can be achieved by testing the meter at 25% of the meter's rating if the manufacturer's original test certificate indicates a linear curve between 25% and 100% of the rated flow range.

‡ The bypass meter should be tested in accordance with the appropriate test requirements for the type of meter used.

†† Quantity should be one or more full revolutions of the test hand but not less than three minutes running.

# Test Bench Manual

# Installation, Operation, and Maintenance for Ford Water Meter Testing Equipment

## Warranty

All merchandise is warranted to be free from defects in material and factory workmanship. We will provide, free of charge, new products in equal quantities for any that prove defective within one year from date of shipment from our factory. Manufacturer shall not be liable for any loss, damage, or injury, direct or consequential, arising out of the use of or the inability to use the product. Before using, user shall determine the suitability of the product for his intended use and user assumes all risk and liability whatever in connection therewith. No claims for labor or consequential damage will be allowed. The foregoing may not be changed except by agreement signed by an officer of the manufacturer.

### **Please Note:**

Consult the Ford Meter Box Company, Inc. website ([www.fordmeterbox.com](http://www.fordmeterbox.com)) for the most recent catalog information. The Ford Meter Box Company considers the information in this catalog to be correct at the time of publication. Items and option availability, including specifications, are subject to change without notice. Please verify that your product information is current.