



AVK SERIES 34 WALL MOUNTED & TELESCOPIC POST INDICATORS, UL LISTED, FM APPROVED FIELD MAINTENANCE AND INSTRUCTION MANUAL

TABLE OF CONTENTS

EXPLODED ASSEMBLY / PARTS LIST INTRODUCTION / DESCRIPTION

- MAINTENANCE
- TOOL REQUIREMENTS
- ADJUSTING TARGET SERIES 3400
- ADJUSTING TARGET SERIES 3480
- MOUNTING SERIES 3400 TO VALVE
- ADJUSTING TO GROUND LEVEL
- WALL POST SELECTION CHART
- MOUNTING SERIES 3480 TO VALVE
- INSTALLATION OF A SUPERVISORY SWITCH

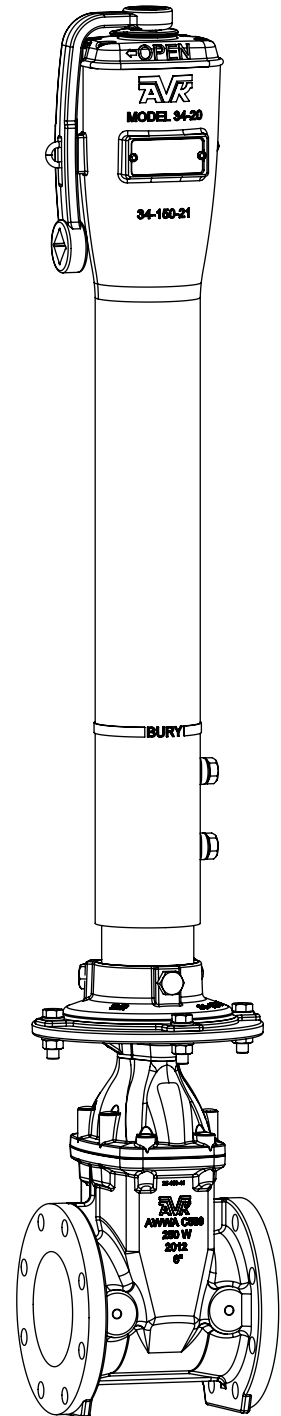
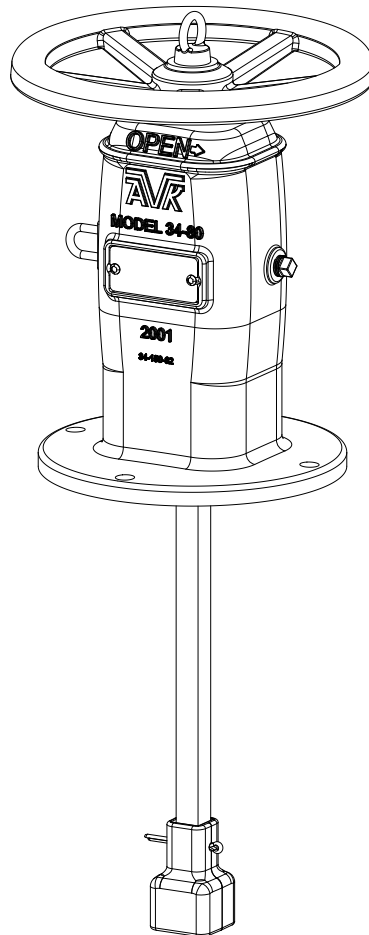

* For Series 3400 Assemblies manufactured after 8/12.

Maintenance Manual Series 34

*Subject to change without notice. (rev.09/12 D)

American AVK Series 34 Indicator Posts Exploded Parts Breakdown

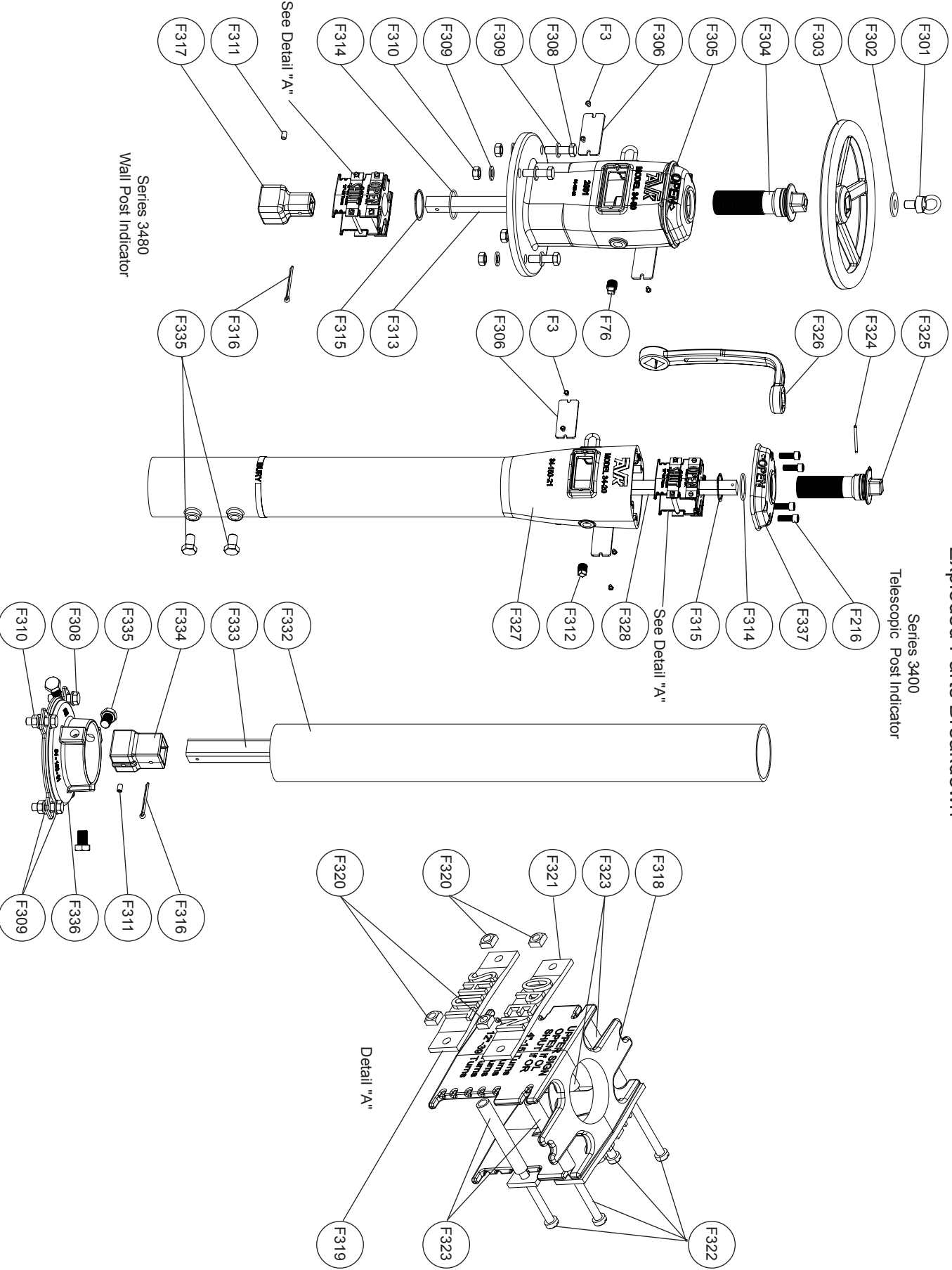

Fig. 1

Item No.	Description	Material
F216	Bonnet Bolt	Zinc Plate, 304, 316 Stainless steel
F3	Window Screw	316 Stainless steel
F301	Eyebolt	Zinc Plated Steel
F302	Eye Bolt Washer M16x50x3	Zinc Plated Steel
F303	Handwheel (3480)	Grey Iron, ASTM A126, "B"
F304	Stem Nut - Series 3480	Copper Alloy
F305	Wall Post Head	Ductile Iron, ASTM A536
F306	Window	Acrylic (PMMA)
F308	Flange Bolt	Zinc Plate, 304, 316 Stainless steel
F309	Flange Bolt Washer	Zinc Plate, 304, 316 Stainless steel
F310	Flange Bolt Nut	Zinc Plate, 304, 316 Stainless steel
F311	Wrench Nut Adapter Set Screw	304 Stainless steel
F312	1/2" Pipe Plug	Zinc Plated Steel
F313	Wall Post Stem	Mild Steel
F314	Stem Nut O-ring	NBR
F315	Stem Nut Snap Ring	316 Stainless steel
F316	Cotter Pin	316 Stainless steel
F317	Wrench Nut Adapter (3480)	Ductile Iron, ASTM A536
F318	Target	Copper Alloy
F319	Shut Plate	Painted Aluminum
F320	Plate Nut	Zinc Plated Steel
F321	Open Plate	Painted Aluminum
F322	Plate Attachment Screw	Zinc Plated Steel
F323	Target Spacer	Mild Steel
F324	Upper Stem Attachment Pin (3400)	316 Stainless steel
F325	Stem Nut - Series 3400	Copper Alloy
F326	Operating Wrench	Ductile Iron, ASTM A536
F327	Telescopic Post Head/Upper Barrel	Ductile Iron, ASTM A536
F328	Telescopic Post Upper Stem	Mild Steel
F332	Lower Barrel	PVC - DR14 UL Listed
F333	Lower Stem	Mild Steel
F334	Wrench Nut Adapter (3400)	Ductile Iron, ASTM A536
F335	Telescopic Post Attachment Bolt	Zinc Plate, 304, 316 Stainless steel
F336	Bell Adapter	Ductile Iron, ASTM A536
F337	Bonnet	Ductile Iron, ASTM A536

MAINTENANCE

INTRODUCTION / DESCRIPTION:

American AVK supplies two models of Indicator Posts for valve sizes 4" through 16". The model 3400, Telescopic Indicator Post, and the model 3480, Wall Post indicator. Both models are UL listed and FM approved. (Note: FM approval to 14")

TOOL REQUIREMENTS:

INCH AND METRIC WRENCH / TOOL REQUIREMENTS FOR AMERICAN AVK POST INDICATORS

Description/Item Number	Tool
Post Indicator Stem Nut (F304,F325)	Stem Operating Wrench (3400)
Target Plate Screws (F322)	Flat blade screwdriver
Wrench Nut Adapter Cotter Pin(F316)	Standard Pliers
Stem Nut Snap Ring (F315)	External Snap Ring Pliers
1/2" Pipe Plug (F312)	Adjustable Wrench
Target Plate Nuts (F320)	7/16" 11mm
Window Screw (Allen) (F3)	5/32" 4mm
Wrench Nut Adapter Set Screw (Allen) (F311)	15/64" 6mm
Flange Bolts/Nuts (F308,F310)	15/16" 24mm
Attachment/Adjustment Bolts (3400) (F329)	1-1/4" 30mm
Bonnet Bolts	3/8" 10mm

MAINTENANCE:

ADJUSTING THE TARGET (FOR SERIES 3400 TYPE INDICATORS): (For assemblies made after 8/12)

NOTE:

For an "open left" valve the "OPEN" sign should be mounted above the "SHUT" sign. (Fig. 2B) For an "open right" valve the "SHUT" sign should be mounted above the "OPEN" sign. (Fig. 2C).

1. With a 3/8", (10mm) allen wrench, remove the four Bonnet Bolts (F216) attaching the Bonnet (F337), to the Head/Upper Barrel Assembly (F327). (See Fig. 2A).
2. Pull the Bonnet and Target Assembly away from the Head/Upper Barrel.
3. If the Post Indicator is to be mounted on an open left valve, the "OPEN" Plate (F321) remains in the top position of the Target (F318). (See Fig. 2B).
4. To configure for "open right" remove the Plate Attachment Screws (F322), and Plate Nuts (F320) with a flat bladed screwdriver and 7/16", (11mm) wrench. Switch the locations of the "OPEN" and "SHUT" Plates. The "SHUT" Plate F319, should be mounted on top. (See Fig. 2C).
5. Re-attach the associated hardware. Ensure that the "OPEN" Plate is in the correct location for the size of valve that the Post Indicator is being mounted on.

NOTE: Each set of dimples in the target is marked for the correct valve size (4" through (12-16")). The Target Spacer (F323) should always be be mounted on the Attachment Bolts that attach the "OPEN" plate. (See Fig. 3, on page 5)

6. Lift the re-assembled post indicator Bonnet/Target Assembly onto the Head/Upper Barrel Assembly. Make sure the upper stem rod slides into the lower stem rod.
7. Install and tighten the four Bonnet Bolts (F216) attaching the Bonnet (F337) to the Head/Upper Barrel Upper Barrel Assembly (F327) .

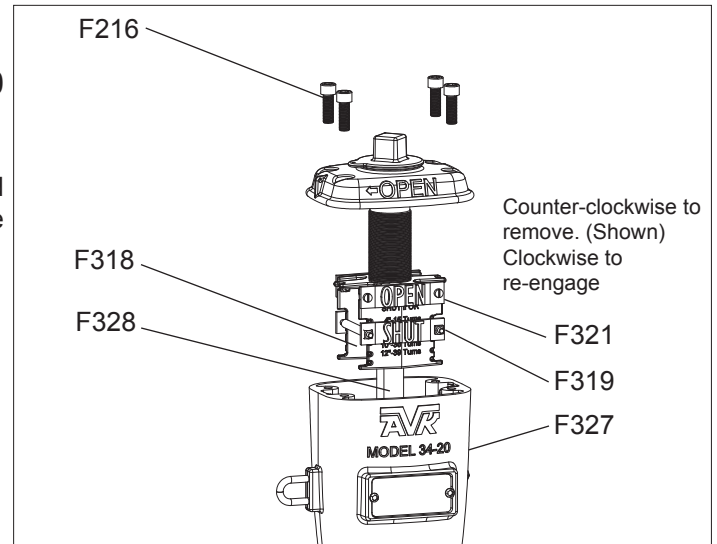

Fig. 2A

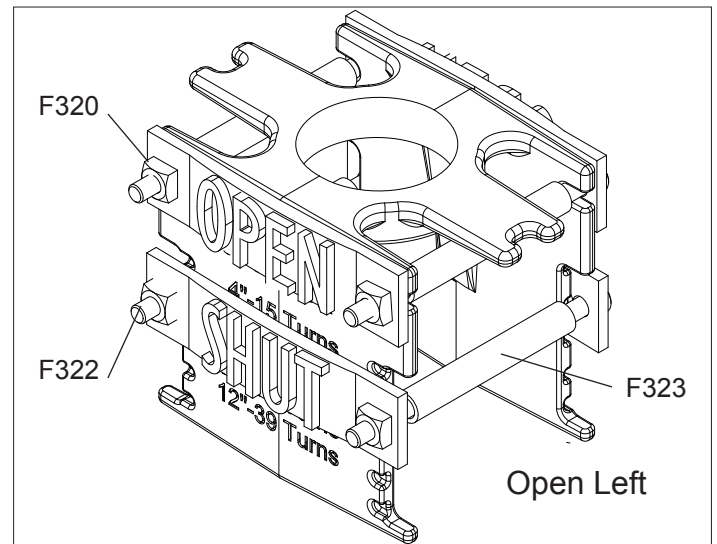

Fig. 2B

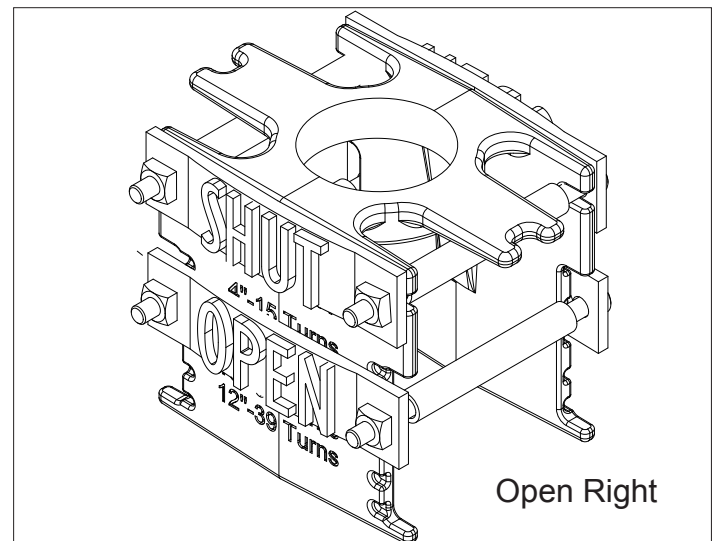

Fig. 2C

MAINTENANCE

MOUNTING THE TELESCOPING POST INDICATOR (SERIES 3400) ONTO A VALVE:

NOTE: If the post indicator signs have not been adjusted to the correct valve size and opening direction, go to the section for "Adjusting the Target". The sign adjustment can be done after the post indicator has been mounted onto a valve but is much easier to adjust before the post indicator is mounted on a valve. In September 2010, American AVK switched series 34 post indicators from a preset 4-inch valve to a preset 6-inch valve. Refer to "ADJUSTING THE TARGET (FOR SERIES 3400 TYPE INDICATORS):"

CAUTION: If the Target assembly has not been adjusted correctly, it is possible for the Target to disengage from the Stem Nut. If this happens, the Target assembly will come to rest against the top of the Upper Barrel where it can be retrieved for proper adjustment. (Follow Steps 4&5 in the ADJUSTING THE TARGET FOR SERIES 3480)

1. Operate the valve so that it is either fully open or fully closed.
2. Using the Operating Wrench (F326), or an adjustable wrench, turn the stem nut on the post indicator until either the "OPEN" or the "SHUT" sign is centered in the window. The sign, "OPEN" or "SHUT", must match the gate position of the valve.

NOTE: The "OPEN" or the "SHUT" Plates may require minor adjustment to match the position of the mating Valve Wrench Nut. Slight offset of the Plates in relationship to the centerline of the Window is acceptable.

3. If present, remove the masonite cover from under the post indicator Bell Adapter (F336) with a 15/16", (24mm) wrench.

CAUTION: The lower stem will slide out if the post indicator is lifted vertically.

4. Holding the Lower Stem (F333) so that it will not slide completely out of the Lower Barrel (F332), lift the post indicator above the valve. (See Fig. 4A)

NOTE: The Wrench Nut Adapter (F334) is pre-attached to the Lower Stem (F333) at the Factory.

5. Position the post indicator Wrench Nut Adapter (#334) onto the valve wrench nut and tighten the Wrench Nut Adapter Setscrew (F311) with a 15/64", (6mm) Allen wrench (key). (See Fig.4B)
6. Lower the complete post indicator onto the valve post indicator plate of the valve. Align the post indicator Bell Adapter (F336) with the valve post indicator plate and install the four sets of Bolts, Nuts and Washers (F308,F309,F310) using a 15/16", (24mm) wrench. (See Fig.4C)
7. Operate the post indicator and check to see that the target signs are moving in the correct direction in relation to the movement of the valve gate. Cycle the valve completely open and closed to make sure the position of the signs are correct within the post indicator head.

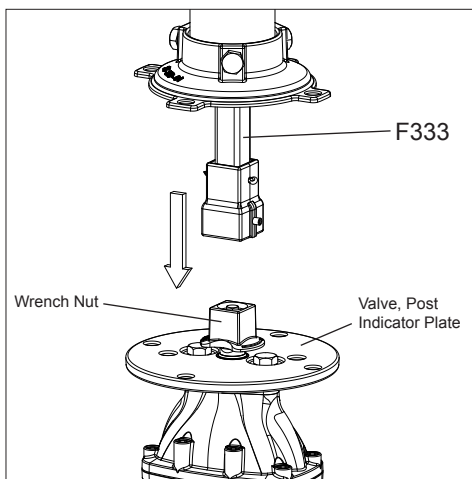

Fig. 4A

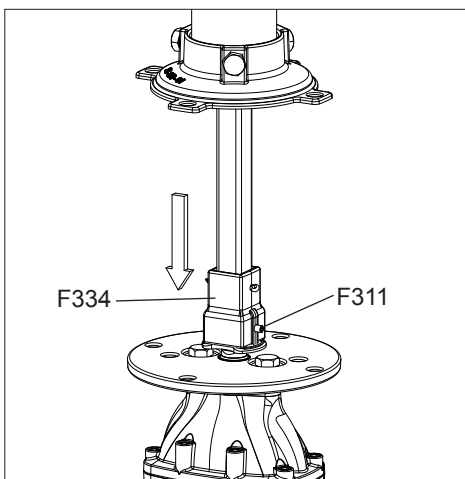

Fig. 4B

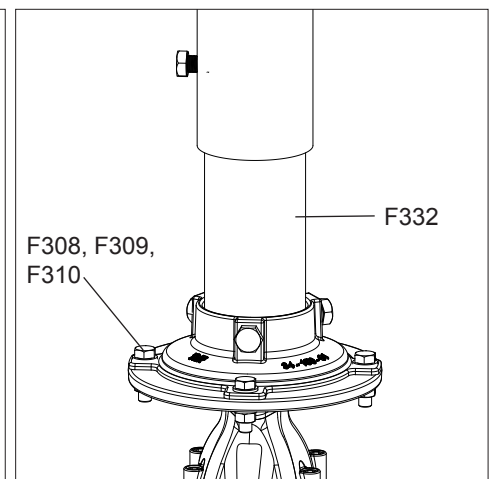
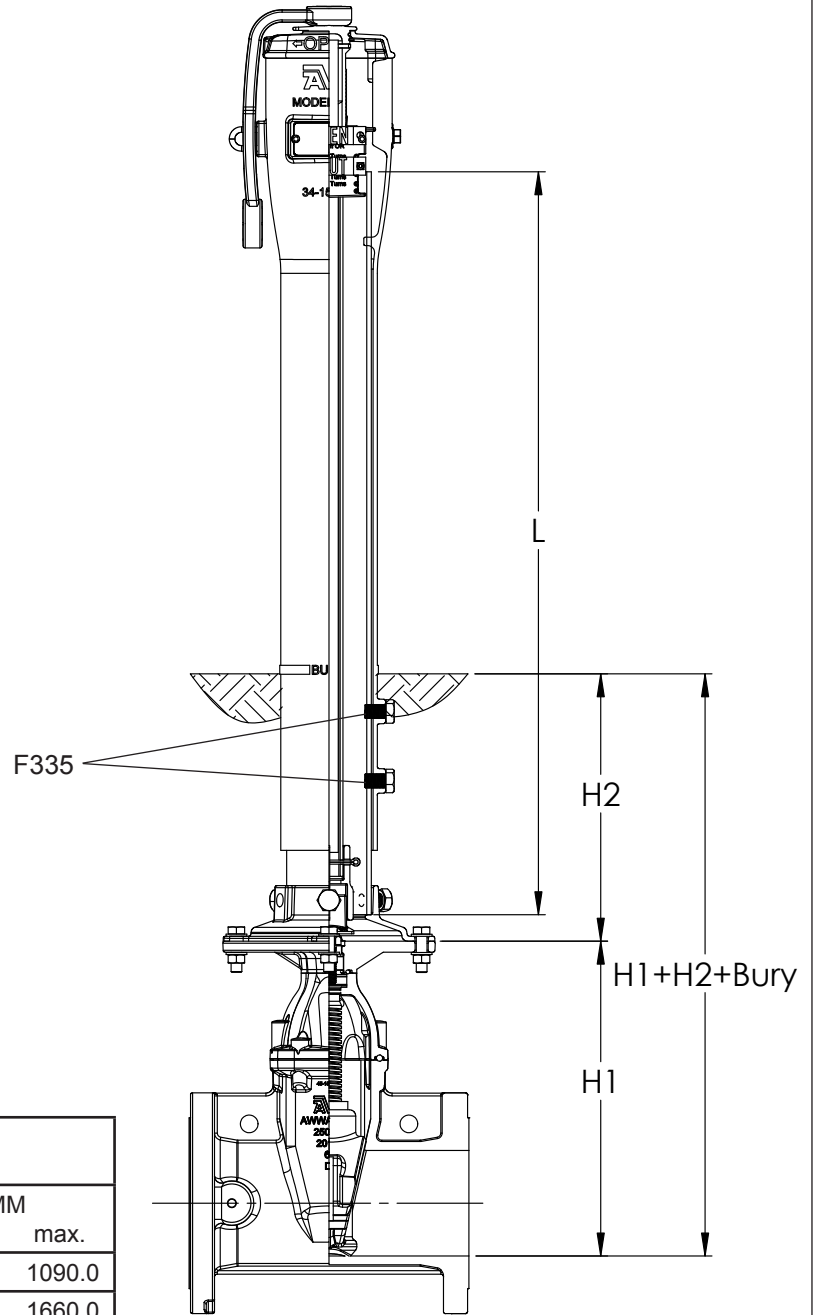

Fig. 4C

ADJUSTING THE POST INDICATOR TO THE GROUND LEVEL

NOTE: All AVK post indicators will telescope 22 ¼" (565mm) from the shortest to the longest length.

1. If you are adjusting the post indicator to the ground level after the post indicator has been installed onto a valve (standing vertically) then you must support the head assembly before proceeding to step 2.
2. Loosen the two Attachment Bolts (F335) positioned at the bottom-side of the upper barrel. (See Fig.5)
3. Lift or lower the upper barrel until the black stripe is at the ground level. The black stripe on the Upper Barrel is located approximately 30" (765mm) below the center of the sign window.
4. Tighten the two bolts on the bottom-side of the upper barrel. (See Fig.5)



Valve Size	H1 (Inches/mm)
4"	13"/330mm
6"	18"/455mm
8"	22.5"/575mm
10"	27"/685mm
12"	31"/785mm
14"-16"	41"/1041mm

Part Number	Length "L" ±4.0		H2			
	Inch	MM	Inch min.	Inch max.	MM min.	MM max.
34-150-61-00-X	42.1	1070.0	20.0"	43.0"	505.0	1090.0
34-150-61-01-X	64.2	1630.0	42.0"	65.0"	1065.0	1660.0
34-150-61-02-X	86.2	2190.0	64.0"	87.0"	1625.0	2210.0

Fig. 5

WALL POST INDICATOR INSTALLATION CHART SERIES 3480

Combine A+B+C to determine which length of Wall Post Stem to order. The length of the Wall Post Stem must be equal to or greater than the sum of A+B+C. If greater than, trim the stem to fall between the dimensions in "Detail A"

Detail A
 "A" = Length of Wall Post Stem. From outside of wall to end of Stem.
 Minimum length of "A" 9.8"- 249mm
 Maximum length of "A" 13.5"- 343mm

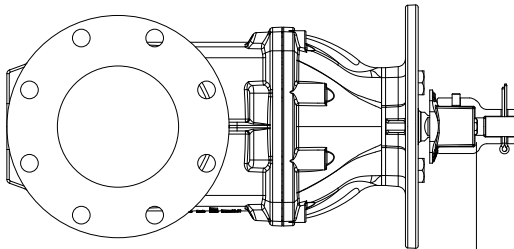

"B" = Distance from top of mounted Valve Wrench Nut to inside of wall.

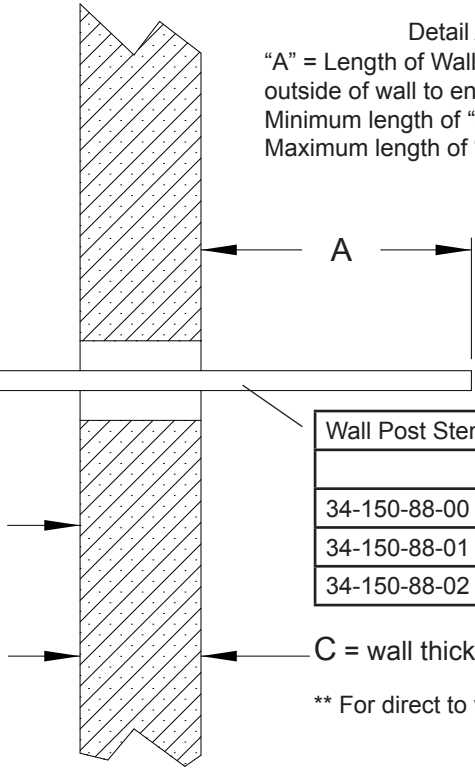

Wall Post Stem Lengths		
	Inch	MM
34-150-88-00	9.8	250 **
34-150-88-01	29.5	750
34-150-88-02	49.2	1250

C = wall thickness
 ** For direct to valve mounting.

Minimum of 4" diameter clearance hole through wall.

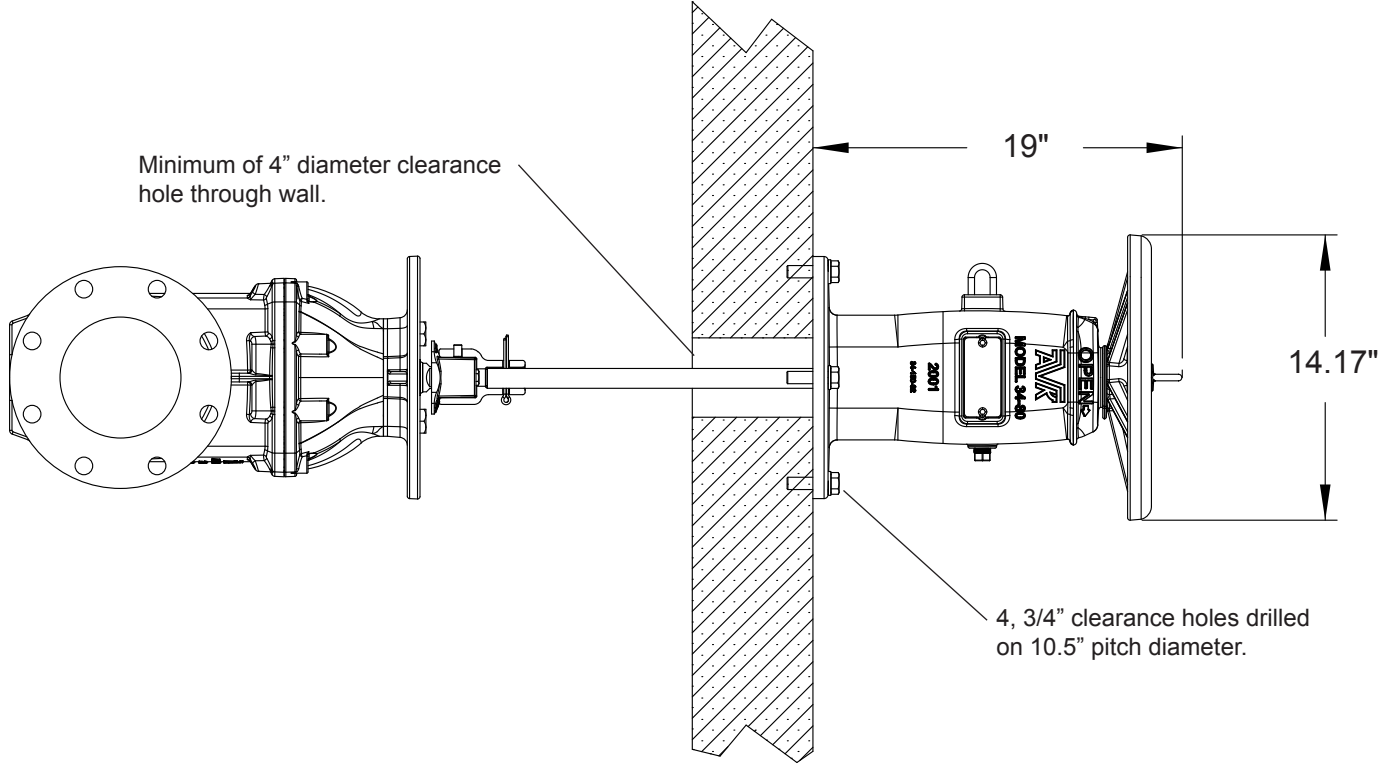

4, 3/4" clearance holes drilled on 10.5" pitch diameter.

MOUNTING THE WALL POST INDICATOR (SERIES 3480) ONTO AN INSTALLED VALVE

NOTE: If the post indicator signs have not been adjusted to the correct valve size and opening direction, go to the section for "ADJUSTING THE TARGET". The sign adjustment can be done after the post indicator has been mounted onto a valve but is much easier to adjust before the post indicator is mounted on a valve. In September 2010, American AVK switched series 34 post indicators from a preset 4-inch valve to a preset 6-inch valve. Refer to "ADJUSTING THE TARGET (FOR SERIES 3400 TYPE INDICATORS): "

CAUTION: If the Target assembly has not been adjusted correctly, it is possible for the Target to disengage from the Stem Nut. If this happens, the Target assembly can be retrieved for proper adjustment. (Follow Step 5 in the "ADJUSTING THE TARGET FOR SERIES 3480")

1. Operate the valve so that it is either fully open or fully closed.
2. Using the Operating Wrench (F326), or an adjustable wrench, or the Handwheel (F303) turn the stem nut on the post indicator until either the "OPEN" or the "SHUT" sign is centered in the window. The sign, "OPEN" or "SHUT", must match the gate position of the valve.

NOTE: The "OPEN" or the "SHUT" Plates may require minor adjustment to match the position of the mating Valve Wrench Nut. Slight offset of the Plates in relationship to the centerline of the Window is acceptable.

3. Remove the masonite cover from under the Wall Post Indicator Head (F305) with a 15/16", (24mm) wrench.

NOTE: The Wall Post Stem (F313) and Wrench Nut Adapter (F317) are pre-assembled at the factory. Locktite has been applied to the threads of the Wrench Nut Set Screw (F311) to prevent loss during shipment.

4. A minimum 4" diameter access hole is required to install the Wall Post Stem Assembly. Insert the Stem Assembly through the wall and align the Wrench Nut Adapter (F317) with the Valve Wrench Nut. Slide the adapter over the valve wrench nut until it stops against the bottom flange of the wrench nut. Tighten the Set Screw (F311) to secure the adapter. (See Wall Post Installation Chart Series 3480)
5. Measure and cut if necessary, the end of the Wall Post Stem according to dimensions in "Detail A" of the Wall Post Installation Chart.

NOTE: The Wall Post Head has four, 3/4" mounting holes on a 10.5" pitch diameter. Mating mounting hardware should be installed prior to Step 6.

6. Using a sufficient supporting device, lift Wall Post Head Assembly and align the internal Stem Nut square relief with the Wall Post Stem. Minor adjustment of the Handwheel may be necessary to position the square relief correctly. (See Fig. 6)
7. Slide the Wall Post Head up to the wall and mount with appropriate hardware.
8. Operate the post indicator and check to see that the target signs are moving in the correct direction in relation to the movement of the valve gate. Cycle the valve completely open and closed to make sure the position of the signs are correct within the post indicator head.

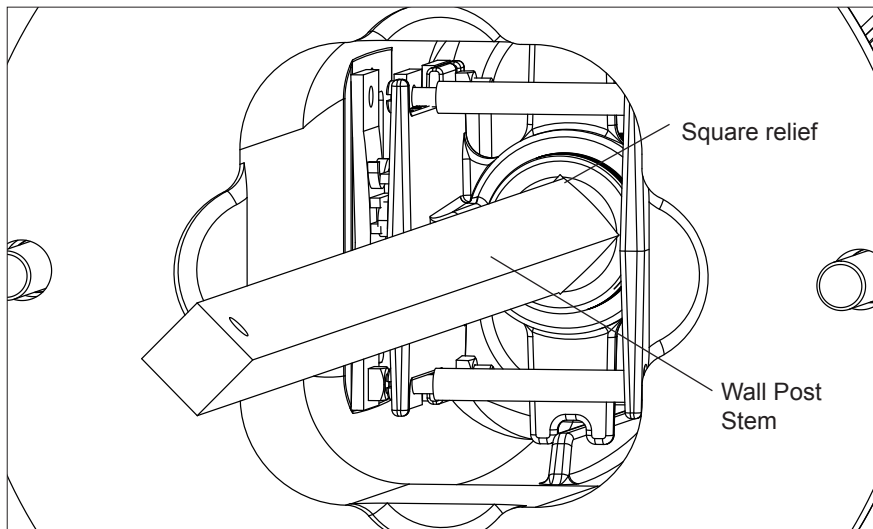

Fig. 6

