

SUBMITTAL INFORMATION

Repair Clamps - (F1-xxxx-Length style)

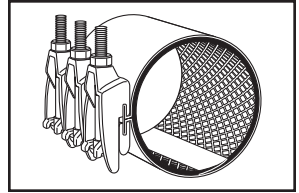

10" AND 12" STAINLESS STEEL REPAIR CLAMPS WITH DUCTILE IRON LUGS

Optional Stainless Taps
ASTM A240 type 304 stainless steel TIG welded to band. Available with AWWA or I.P. threads.

Band
ASTM A240 type 304 stainless steel

Lugs
Ductile Iron per ASTM A536
Finish: E-coat epoxy

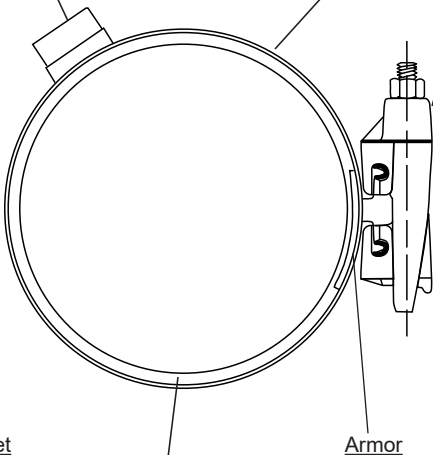

Nuts and Bolts
High strength, low alloy steel per ASTM A242 and AWWA C111/A21.11

Optional
304 Stainless Steel Bolts and Nuts

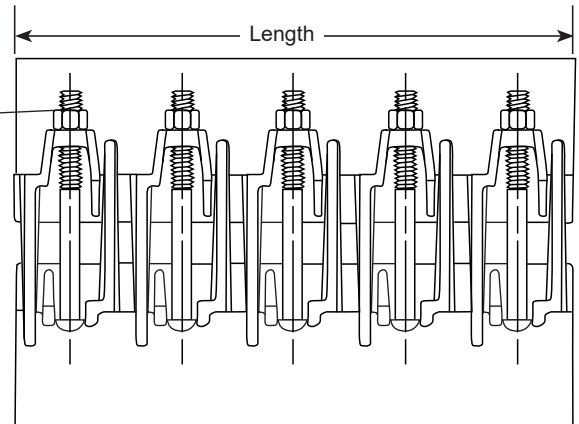

Gasket
Gridded Virgin SBR compounded for water service, per ASTM D2000. NBR (Buna-N) is available as optional material.

Armor
ASTM A240 type 304 heavy gauge stainless steel, mold bonded into the gasket to ensure uniform compression against the pipe

OUTLET THREAD TAP CODE

CC (AWWA) Thread		IP Thread	
THREAD	CODE NUMBER	THREAD	CODE No.
3/4" CC	-CC3	3/4" IP	-IP3
1" CC	-CC4	1" IP	-IP4
1-1/4" CC	-CC5	1-1/4" IP	-IP5
1-1/2" CC	-CC6	1-1/2" IP	-IP6
2" CC	-CC7	2" IP	-IP7

NOM. PIPE SIZE	PIPE O.D. RANGE	LENGTH AND APPROXIMATE WEIGHT (LBS.)						BOLT SIZE	BAND THICKNESS	CATALOG NUMBER	✓ SUBMITTED ITEM(S)
		7.5"	10"	12.5"	15"	20"	30"				
10"	10.10 - 10.50							5/8" x 6-1/2"	20 GA.	F1-1050-Length	
	10.64 - 11.04						F1-1104-Length				
	11.04 - 11.44	16	21	26	31	41	62			F1-1144-Length	
	11.34 - 11.74									F1-1174-Length	
	11.75 - 12.15									F1-1215-Length	
12"	12.00 - 12.40									F1-1240-Length	
	12.10 - 12.50	17	22	28	33	44	67			F1-1250-Length	
	12.62 - 13.02									F1-1302-Length	
	13.10 - 13.50									F1-1350-Length	
	13.40 - 13.80									F1-1380-Length	
	13.70 - 14.10	18	23	29	35	46	70			F1-1410-Length	
	14.00 - 14.40							F1-1440-Length			
Number of Bolts		3	4	5	6	8	12				

FEATURES

- Drop-in bolt design allows bolts to remain attached - no loose parts to lose in the ditch
- Also available in two- and three- section clamps for a wider range of pipe sizes and tolerances
- Optional Outlet Taps are available for repair of service line pull-outs. Add tapping code to catalog number
- All welds are fully passivated to restore corrosion resistant characteristics of stainless steel
- Removable lugs
- Certified to ANSI/NSF Standard 61

The Ford Meter Box Company considers the information in this submittal form to be correct at the time of publication. Item and option availability, including specifications, are subject to change without notice. Please verify that your product information is current.



The Ford Meter Box Company, Inc.
P.O. Box 443, Wabash, Indiana U.S.A. 46992-0443
Phone: 260-563-3171 / Fax: 800-826-3487
Overseas Fax: 260-563-0167
www.fordmeterbox.com

09/11/19

Submitted By:



36 Hudson Rd
Sudbury MA 01776



800-225-4616
www.tisales.com