



# OEM Manual

MODEL 4020™ - 3 ½ Digit  
DRUM SCALE

**Scaletron™ Industries, Ltd.**  
Bedminster Industrial Park  
53 Apple Tree Lane  
P.O. Box 365  
Plumsteadville, PA 18949 USA

**Toll Free: 1-800-257-5911 (USA & Canada)**  
Phone: (+1) 215-766-2670 (international)  
Fax: (+1) 215-766-2672  
E-mail: [info@scaletronscales.com](mailto:info@scaletronscales.com)  
Website: [www.scaletronscales.com](http://www.scaletronscales.com)

These instructions generally describe the installation, operation, and maintenance of subject equipment. The manufacturer reserves the right to make engineering refinements that have not been described herein. Should any questions arise that may not be answered specifically by these instructions, they should be directed to **SCALETRON INDUSTRIES, LTD.**, or our sales agent for a response.

All possible precautions were taken in packaging each equipment item to prevent shipping damage. Carefully inspect each item and report damages immediately. Report damage claims to shipping agent involved for equipment shipped F.O.B. job site. Do not install any damaged equipment.

All instructions given on any labels, or attached tags, should be followed. Carefully inspect all packing material before discarding it to prevent loss of accessories, mounting hardware, spare parts, or instructions.

<b>Table of Contents</b>	<b>Page</b>
<b>I. GENERAL DESCRIPTION.....</b>	<b>1</b>
<b>II. SPECIFICATIONS.....</b>	<b>1</b>
<b>III. ASSEMBLY AND START-UP.....</b>	<b>2</b>
<b>IV. GENERAL USE INSTRUCTIONS.....</b>	<b>2-3</b>
<b>V. CALIBRATION PROCEDURE.....</b>	<b>3</b>
<b>VI. TROUBLESHOOTING.....</b>	<b>3 – 4</b>
<b>VII. BOARD DIAGRAM AND 4-20 CONNECTION DIAGRAM.....</b>	<b>5 - 6</b>

## **I. General Description:**

The Model 4020™ Digital Drum Scale is available with 12” or 16” discs and was designed to provide the accurate weight of cylinders the same diameter and smaller. The maximum net weight is 199.9 lbs./kg. for 0.1 lbs./kg. resolution. If maximum net weight is over 199.9, the decimal is blanked at the factory, and the display can read 1999 lbs./kg., but the maximum weight rating on the base is 600 lbs. and should not be exceeded. Maximum tare weight is 150 lbs.

The low profile design of the platform, 1 ½ ”, allows for safe and easy loading and unloading of cylinders. The printed circuit board contains a power supply section and a separate tare and span control. The weighmeter electronics are housed in a NEMA 4X enclosure for mounting on the wall.

### **Standard Parts**

1 Base assembly  
1 Weighmeter  
1 Power Cord  
1 Technical Manual

### **Available Options**

A. Remote mounting of standard enclosure  
B. Loadcell Cable

## **II. Specifications:**

**Display:** 3 ½ Digit LCD with minus sign liquid crystal display, 0.5” high, seven segment

**Resolution:** 199.9 lbs./kg. X 0.1 lbs./kg., 600 lbs./(272 kg.) X 1 lbs./kg.

**Load Cell Excitation:** 12 VDC Power 3 Cells

**Zero Adjustment:** Internal potentiometer, external tare knob

**Overload:** Blanks with “1” displayed at far left of display

**Accuracy:** +/- 0.5% Capacity

**Power:** 85 – 265 VDC, 50/60 Hz single phase, 0.42 Amps. DEDICATED - ISOLATED POWER WITH EARTH GROUNDING

### III. Assembly and Start-up:

The Model 4020™ Drum Scale is shipped disassembled. Assembly instructions are as follows:

The load cells are secured to discs and mounted in the base housing. All wire connections in the base have been made and sealed at the factory. The digital weighmeter is assembled and calibrated to the base at the factory. The customer must mount the indicator on the wall. The wires must be run through the strain relief, connected to connector and plugged into indicator before scale is operated.

#### **Steps are as follows:**

**Step 1:** Remove all parts from box and inspect for damage, broken wires, cracks in indicator, etc. Any shipping damage must be reported to carrier.

**Step 2:** Place the scale on a solid dry surface. Clear the area of all debris where scale will sit.

**Step 3:** Weigh platform must be bolted to floor; clearance holes are provided in each corner for 3/8" anchor bolts. Make bolts snug, but do not over tighten.

**Step 4:** Run conduit if required. Make hole in indicator box for conduit if used. If not, make 1/2" hole for liquid tight strain relief provided. Feed the wire up through the strain relief and tighten the fitting. Fasten indicator to the wall. Connect wires to 6 pin connector provided (TB 1) according to the following code:

**TB1 : Ret:** Common, 4-20mA Return\*

**Out:** + 4-20mA Output\*

**G:** Green = + Signal

**W:** White = - Signal

**Bk:** Black = - Supply Voltage

**R:** Red = + Supply Voltage

\*Connect your wires here if you are using 4-20mA output. Refer to the wiring diagram on page 5 and 6 for 4-20mA connections. Jumper J-4 will need jumper in the top two pins for loop powered, and the bottom two pins for scale powered (with board oriented as in drawing pg 5.) Close the weighmeter and apply power as required: Standard Unit requires a 120 Volt power source (power supply voltage range spans: 85 Volt to 265 Volt AC)

**Step 5:** Allow approximately 15 minutes warm up time before using the scale.

### IV. General Use Instructions:

**TARE ADJUSTMENT:** The tare knob, located on the front of weighmeter, allows either zeroing the scale to determine the gross weight of the drum, or presetting the known tare weight of a drum or cylinder before it is placed on the scale. With the scale platform empty, the operator can determine the tare weight (normally marked on each cylinder). When using a drum, weigh empty container and mark drum with weight. The operator would then turn the tare knob in the direction required to set a negative (-) reading on the display equivalent to tare weight of the cylinder.

**Example:**

1. Cylinder or drum weight: 75 lbs.
2. Without cylinder or drum on scale, adjust tare knob until display reads -75.0.

\*\* Clockwise rotation of knob increases tare. \*\*  
\*\* Counterclockwise rotation of knob decreases tare. \*\*

**Note:** When other fittings, etc., are to be secured to the cylinder or drum, the weight of these items should be added to the tare weight of the cylinder or drum in order to have accurate tare setting. When a cylinder or drum is placed on the scale, the display will then indicate the actual net weight, or weight of its contents.

**ALTERNATE TARE METHOD:** Cylinders are sometimes filled to a predetermined weight. If this is the case, the operator can place the cylinder on the scale, attach all hoses, fittings, etc., and then adjust the tare knob until the display reads that positive (+) predetermined weight.

**Example:** Cylinder is known to have 150 lbs. of contents. The operator would place cylinder or drum, fittings, hoses, etc., on the scale, then adjust the tare knob until display reads 150.0 lbs. positive.

**Note to Operator:** It is imperative that the cylinder be completely on the disc and that no part of the cylinder or drum touches the surrounding base plate.

## V. Calibration Procedures:

*The Model 4020™ Drum Scale is **calibrated at the factory** to within specified accuracy and is calibrated to standards traceable to the Bureau of Weights and Measures. **NO FURTHER CALIBRATION SHOULD BE NECESSARY.** If the electronics, or load cells in the base, are replaced, the following calibration procedure should be used.*

1. Plug the AC cord into a well grounded receptacle. There is no power on-off switch, so power is applied as soon as it is plugged in.
2. Allow approximately 15 minutes warm up time before calibration.
3. While weighmeter is warming up, proceed to check under cylinder support disc to make sure there is no debris under platform.
4. Turn back tare knob clockwise until you reach the lock, and check display. There should be at least +10 lb. If the number is not close to this, please adjust R-6 on the pc board to allow for at least +10 lb.
5. Adjust tare knob on front of weighmeter until scale reads zero with no weight on platform. Adjust R-22 to set your 4 mA reading to represent 0 lb. on the display. (Your mA meter will be connected at the locations Out and Ret on the connector for this reading, with NO wires on the terminal.)
6. Place a known weight on disc as close to center as possible. Test weight should be equal to ½ of capacity or greater.
7. Adjust R-15 until the display shows the weight shows the amount of weight you are calibrating with.
8. You must now calculate the correct milliamp reading for this weight that you are using to calibrate. The formula is as follows: 16mA divided by the number of pounds in the maximum net weight of scale. (Ex: your scale is set for 0 to 500lb. net weight. You would take 16 and divide by 500. This will give you the number of milliamps per pound). Using the number of milliamps per pound, multiply it times the amount of weight you are calibrating with. (You are calibrating with 400 lb. Multiply 400 x the number of milliamps per pound.) To adjust this number, then add 4 milliamps to it. (Ex. In the example we use, the result is 16.8 mA. You would turn the pot R-19 until your meter displays 16.8mA).
9. Calibration is complete when specified accuracy is obtained.

## VI. Troubleshooting:

1. If display reads “-1”:
  - A. Gross underload, turn tare knob clockwise. Numbers should reappear and can be adjusted to tare weight or zero as required.
  - B. Check load cell connections **at indicator** and connect wires per chart on Page 3 & 4.
2. If display reads “1”:

- A. Gross overload, if starting point was zero, the weight is more than 199.9 lbs. for .1 resolution, weight is more than 199.9 lbs., or 1999 lbs. for 1.0 resolution.
  - B. If starting point was -150 lbs. then the weight is more than 349.9 lbs. Remove weight and recheck tare setting.
  - C. Check load cell connections according to Page 3 & 4.
3. If no display:
- A. Check power to weighmeter.
  - B. Check green light on power supply board. It should be lit. If not lit, it is shorted out.
4. **Other Problems:**
- A. Consult factory:

**USA & Canada Toll-Free: (800) 257-5911**  
**Tel: (+1) 215-766-2670 ♦ Fax: (+1) 215-766-2672**

**Notice: Do not return any equipment without first contacting the factory. A return authorization number will be issued and it must be marked on all materials returned to the factory, accompanying a letter that explains the problem specifically. A Serial Number will also be required. It is located inside the indicator box.**

## **VII. Board Diagram:**

©2010 Scaleton Industries Ltd., Plumsteadville, PA Scaleton, Scaleton Sets the Standard In Corrosion Resistance, Model 1020-1, 1020-2, Model 1099, Model 2305, Model 2306, Model 2307, Model 2308, Model 2310, Model 2330, Model 2350, Model 2352, Model 2353, Model 3001, Model 3002, Model 3003, Model 3004, Model 3005, Model 3006, Model 3050-1, Model 3050-2, Model 4000SS, Model 4010, Model 4020, Model 4021, Model 4030, Model 4040, Model 4040IBC, Model 4041, Model 4042, Model 4042WB, Model 5305 are trademarks of Scaleton Industries Ltd. Total Electronic System is a service mark of Scaleton Industries Ltd.  
PRINTED IN THE U.S.A. FEB 2010.

## 3 1/2 digit LCD Board

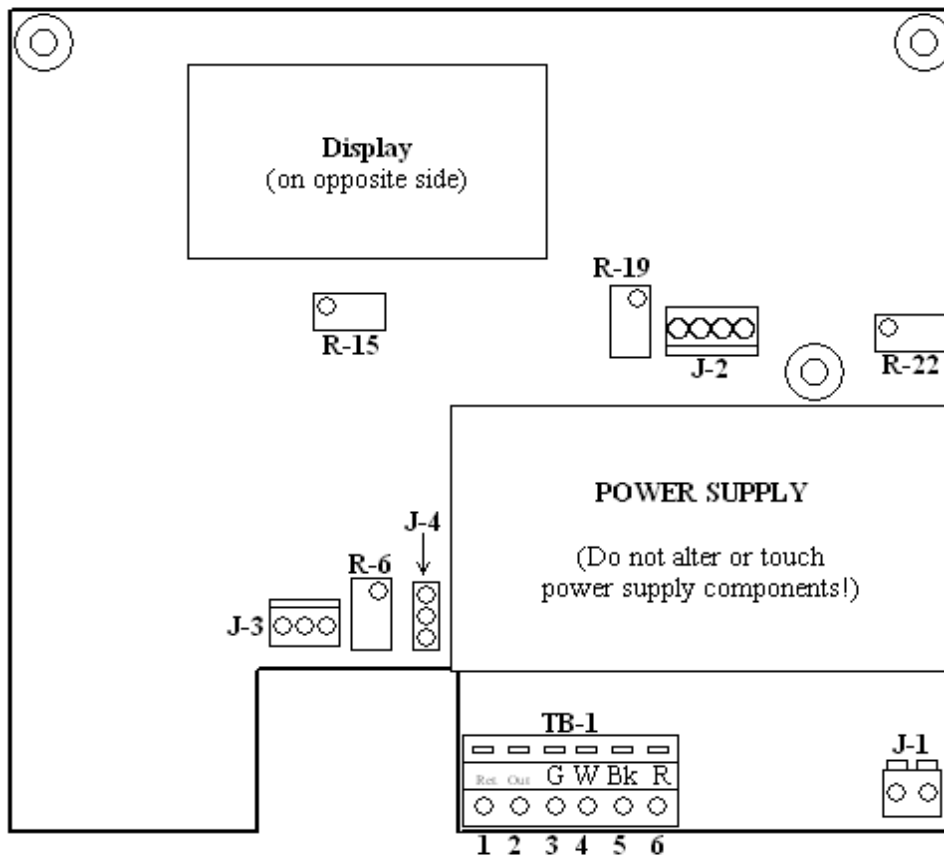

From left to right with P.C. Board as shown, the following connections should be made:  
 (Connector is identified with positions 1-6 from left to right, but is not labeled on the p.c. board.)  
 Sticker on connector identifies the color wires from the base to connect to TB-1.

### TB-1:

- 1 - (Ret) Common, 4-20mA return
- 2 - (Out) + 4-20mA Output
- 3 - Green = G = + Signal
- 4 - White = W = - Signal
- 5 - Black = Bk = - Supply Voltage
- 6 - Red = R = + Supply Voltage

J-1 - Voltage (AC) line connection

J-2 - Optional Low Level Board connection

J-3 - Tare Pot connector

J-4 - Top two pins jumpered for Loop Powered 4-20mA,  
 Bottom two pins jumpered for Scale Powered 4-20mA.

R-6 - tare adjustment

R-15 - weight span

R-19 - 20mA adjustment

R-22 - 4mA adjustment

**4-20mA Diagram:**

*Refer to appropriate diagram:*

**LOOP POWERED DIAGRAM**

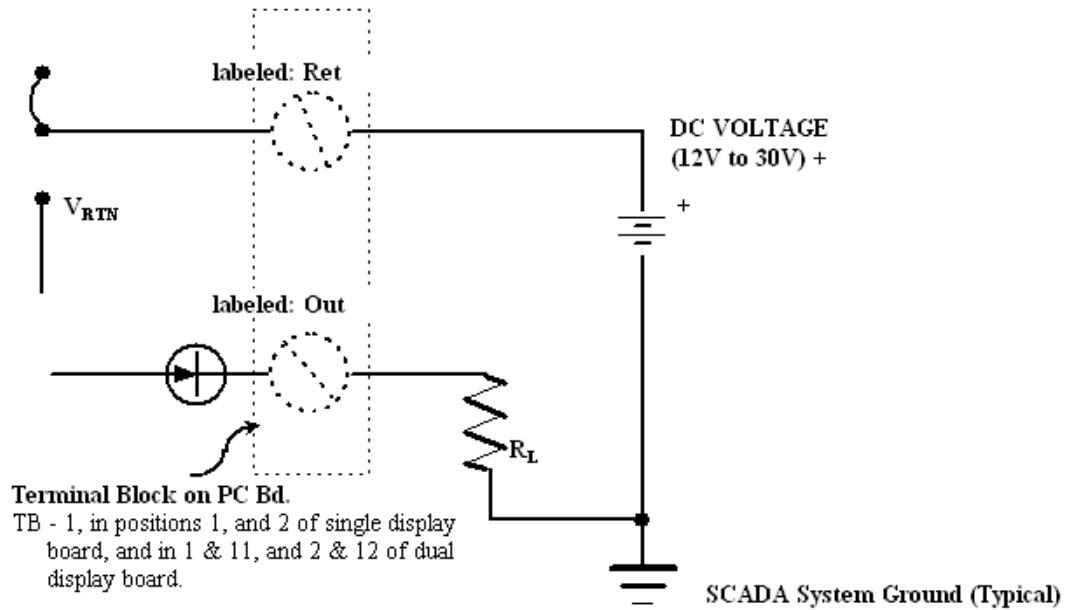

**SCALE POWERED DIAGRAM**

