



OEM Manual

MODEL 2350™ ELECTRONIC
DUAL CYLINDER SCALE

Scaletron™ Industries, Ltd.
Bedminster Industrial Park
53 Apple Tree Lane
P.O. Box 365
Plumsteadville, PA 18949 USA

Toll Free: 1-800-257-5911 (USA & Canada)
Phone: (+1) 215-766-2670 (international)
Fax: (+1) 215-766-2672
E-mail: info@scaletronscales.com
Website: www.scaletronscales.com

These instructions generally describe the installation, operation, and maintenance of subject equipment. The manufacturer reserves the right to make engineering refinements that have not been described herein. Should any questions arise that may not be answered specifically by these instructions, they should be directed to **SCALETRON INDUSTRIES, LTD. OR OUR SALES AGENT** for a response.

All possible precautions were taken in packaging each piece of equipment to prevent shipping damage. Carefully inspect each item and report damages immediately. Report damage claims to shipping agent involved for equipment shipped F.O.B. job site. Do not install any damaged equipment.

All instructions given on any labels, or attached tags, should be followed. Carefully inspect all packing material before discarding to prevent the loss of accessories, mounting hardware, spare parts, or instructions.

TABLE OF CONTENTS	PAGE
I. GENERAL DESCRIPTION.....	1
II. SPECIFICATIONS.....	1 - 2
III. ASSEMBLY AND START-UP INSTRUCTIONS.....	2
IV. GENERAL USE INSTRUCTIONS.....	2 - 3
V. CALIBRATION PROCEDURE.....	3
VI. TROUBLESHOOTING.....	4
VII. BOARD DIAGRAM & 4-20mA CONNECTION DIAGRAM.....	5 - 6

I. General Description:

The Model 2350™ Digital Dual Cylinder Scale is designed for weighing cylinders 11 ¾ inches in diameter and smaller with a maximum net weight of 199.9 lbs. and a maximum tare weight of 150 lbs. The low profile design of the platform (1 ½ ") allows for safe and easy loading of cylinders. A pedestal, crossbar, and chains are provided to secure cylinders in place. The printed circuit board contains a power supply section and two separate tare and span controls, one for each disc. A 4-20 mA output signal is provided for each display. The weigh meter electronics are housed in a NEMA 4X enclosure for mounting on top of the pedestal, or remotely.

STANDARD PARTS

- 1 Base Assembly
- 1 Pedestal
- 1 Crossbar
- 1 Weigh meter
- 1 Power cord
- 1 Bag of Hardware
- 1 Technical Manual
- 2 Chains
- 1 "U" Bolt

AVAILABLE OPTIONS

- A. Remote mounting of standard enclosure
- B. Load Cell Cable
- C. Low Level relay contact

II. Specifications:

Display: LCD 3 ½ digit with minus sign, liquid crystal display, 0.5" high, seven segment

Resolution: Single cylinder 199.9 lbs. x 0.1 lbs. (90 kg. x 0.1 kg.)

Load Cell Excitation: 12 VDC Power 6 Cells

Zero Adjustment: Internal potentiometer, external tare knobs

Overload: Blanks with "1" displayed at far left of display

Accuracy: +/- 0.5% capacity

Power: 85-265 VAC 50/60 Hz single phase, 0.42 Amps. DEDICATED-ISOLATED POWER WITH EARTH GROUNDING

Dimensions: Standard unit 32"W x 17.5"D x 58.75"H

III. Assembly and Start-up instructions:

The Model 2350™ Digital Dual Cylinder Scale is shipped disassembled. Assembly instructions are as follows:

The load cells are secured to discs and mounted in the base housing. All wire connections in the base have been made and sealed at the factory. ***The digital weigh meter is assembled and calibrated to the base at the factory.*** The customer must mount the pedestal, crossbar and chains, indicator, and reconnect wires to the printed circuit board before scale can be operated.

Step 1: Remove all parts from box and inspect for damage – bent metal, broken wires, cracks in indicator, etc. Any shipping damage must be reported **to carrier!**

Step 2: Place the scale on a solid, dry, and even surface. Clear the area of all debris where the scale base will be anchored.

Step 3: Open the weigh meter (indicator) and install one black liquid tight fitting in the center hole. Feed the wire up through the fitting and snug the fitting on the wire. Fasten the indicator to the post. Connect the wires into the connector using the following code:

TB1 – 1: Common, 4-20mA Return*=Ret

TB1 – 2: + 4-20mA Output* = Out

TB1 – 3: Green = G= + Signal

TB1 – 4: White = W= - Signal

TB1 – 5: Black = Bk= - Supply Voltage

TB1 – 6: Red = R= + Supply Voltage

TB1- 7: Brown = Br= - Supply Voltage

TB1- 8: Orange = O= + Supply Voltage

TB1- 9: Blue = Bl= + Signal

TB1-10: Yellow= Y= - Signal

TB1-11: Common, 4-20mA Return*= Ret

TB1-12: +4-20mA Output*= Out

*Connect your wires here if you are using 4-20mA output. Refer to the wiring diagram on page 5 and 6 for 4-20mA connections. Jumper J-4 will need jumper in the top two pins for loop powered, and the bottom two pins for scale powered (with board oriented as in drawing pg 5.)

Insert the wire, being sure not to crimp the insulation in the connector. Using a small screwdriver, push the orange lever down to insert the wire into the proper hole and release the lever to allow the wire to clamp into the connector. The connector holes are labeled according to the color that is inserted there.

Step 4: Secure the cross bar to the post using “U” Bolt, Flat washer, lock washer and acorn nut. Fasten the chain to cross bar with two “S” hooks in the holes provided. The cross bar should be at the proper height to restrain the size cylinder being used.

Step 5: Allow approximately 15 minutes warm up time before using the scale

IV. General Use Instructions:

There are two separate ways to use this scale. **If you know the tare weight (the weight of the empty cylinder) please use the following procedure:**

Begin by allowing 15 minutes of warm up time for the first time use of the scale. With the base empty, add together the tare weight of the cylinder, plus the weight of any equipment that will mount on the cylinder, affecting the weight on the scale, and total that number. This is your

total tare weight. With the scale empty, turn the black tare knob mounted on the outside of the door of the indicator, and turn it counter clockwise to read a negative number that is the tare weight. (For instance, the tare weight is 100 lbs. total. You turn the black tare knob until the scale indicator reads “-100” lb.) Now you may load the full cylinder onto the base and attach any equipment. Your display will read the NET WEIGHT (the weight of the contents only). As you use the contents, the weight will constantly read the net weight. When you are ready to refill, simply remove the used cylinder, adjust the tare weight to read the negative tare weight of the new cylinder and equipment, and load it onto the scale. You are then seeing the Net Weight again.

If you know the net weight of the cylinder (contents weight only), please use this procedure:

With the scale empty, determine the NET WEIGHT of the cylinder you are loading onto the scale. Load the cylinder onto the base and hook up any equipment that may affect the weight reading of the scale. Using the black tare knob on the outside of the indicator box, turn the black knob counter-clockwise until you see the (positive) number that is the net weight (contents). Doing this, you have “tared out” the cylinder weight and equipment weight so that the weight you see is the contents only. As you use the contents, the weight will constantly decrease until it is empty, and it is time to load a new cylinder. Load on the new cylinder, attach all equipment, and adjust the tare knob to read the known Net Weight again. You are ready to use the contents again.

V. Calibration Procedure:

The Model 2350™ Dual Cylinder Scale is calibrated at the factory to within specified accuracy and is calibrated to standards traceable to the Bureau of Weights and Measures. No further calibration is necessary. If the electronics or load cells in base are replaced, the following calibration procedure should be used.

Steps are as follows:

1. Plug the AC Cord into a well-grounded receptacle. There is no power on / off switch, so power is applied as soon as it is plugged in.
2. Allow approximately 15 minutes warm-up time before calibration.
3. While indicator is warming up, proceed to check under cylinder support disc to make sure there is no debris.

Begin with one side of the scale to complete this process, and then return to step four to repeat on other side.

4. WITH NO WEIGHT APPLIED TO THE SCALE, turn the black tare knob on the outside of the door of the indicator in the clockwise direction to make sure that there is *at least* +10 lb. of weight in the tare knob. If not, adjust R-6 to see a positive reading. Once that is established, turn the black tare knob on the door of the indicator counter-clockwise until it stops (DO NOT OVER TURN KNOB OR YOU WILL DAMAGE THE TARE POT!) Once it reaches the most negative reading, make sure you have at least –150 lb. on the display. If the tare span is large, you may get to a –1 reading and this is a weight under-load condition. Turn R-6 until you see a number that is not “below” –199.9 lb.
5. Adjust tare knob on front of weigh meter until scale reads zero with no weight on platform. Adjust R-22 to set the 4mA reading to 0lbs.
5. Place a known weight on the disc, as close to center as possible. Weight should be equal to ½ of capacity, or greater.
6. Adjust R-15 until display reads weight of test weight on scale disc.

7. To complete calibration of 4-20mA output, adjust R-19 for proper 20 mA adjustment reading. Factory setting is for 20 mA at 150.0 lb (68 kg.) unless specified otherwise.
8. Calibration is complete if specified accuracy is obtained. **Repeat for second half of scale.**

VI. **Troubleshooting:**

1. If Display reads “-1”:

- A. Gross under load, turn tare knob clockwise. Numbers should reappear and can be adjusted to tare weight or zero as required.
- B. Check load cell connections at indicator and connect wires per chart on page 2

2. If Display reads “1”:

- A. Gross overload, if starting point was zero, the cylinder weight is more than 199.9 lbs., or kg.
- B. If starting point was -150 lbs. (68 kg.) then the cylinder weight is more than 349.9 lbs. (158 kg.) Remove weight and recheck tare setting.
- C. Check load cell connections according to page 2, Step 4

3. If No Display:

- A. Check power to weigh meter.
- B. Check green light on power supply board. It should be lit. If not lit, it is shorted out.

4. Other problems: (PLEASE HAVE SERIAL NUMBER OF SCALE WHEN CALLING)

- A. Consult factory:

USA & Canada Toll-Free: (800) 257-5911
Tel: (+1) 215-766-2670 ♦ Fax: (+1) 215-766-2672

Notice: Do not return any equipment without first contacting the factory. A return authorization number will be issued and it must be marked on all materials returned to the factory, accompanying a letter that explains the problem specifically. A Serial Number will also be required. It is located inside the indicator box.

VII. Board Diagram:

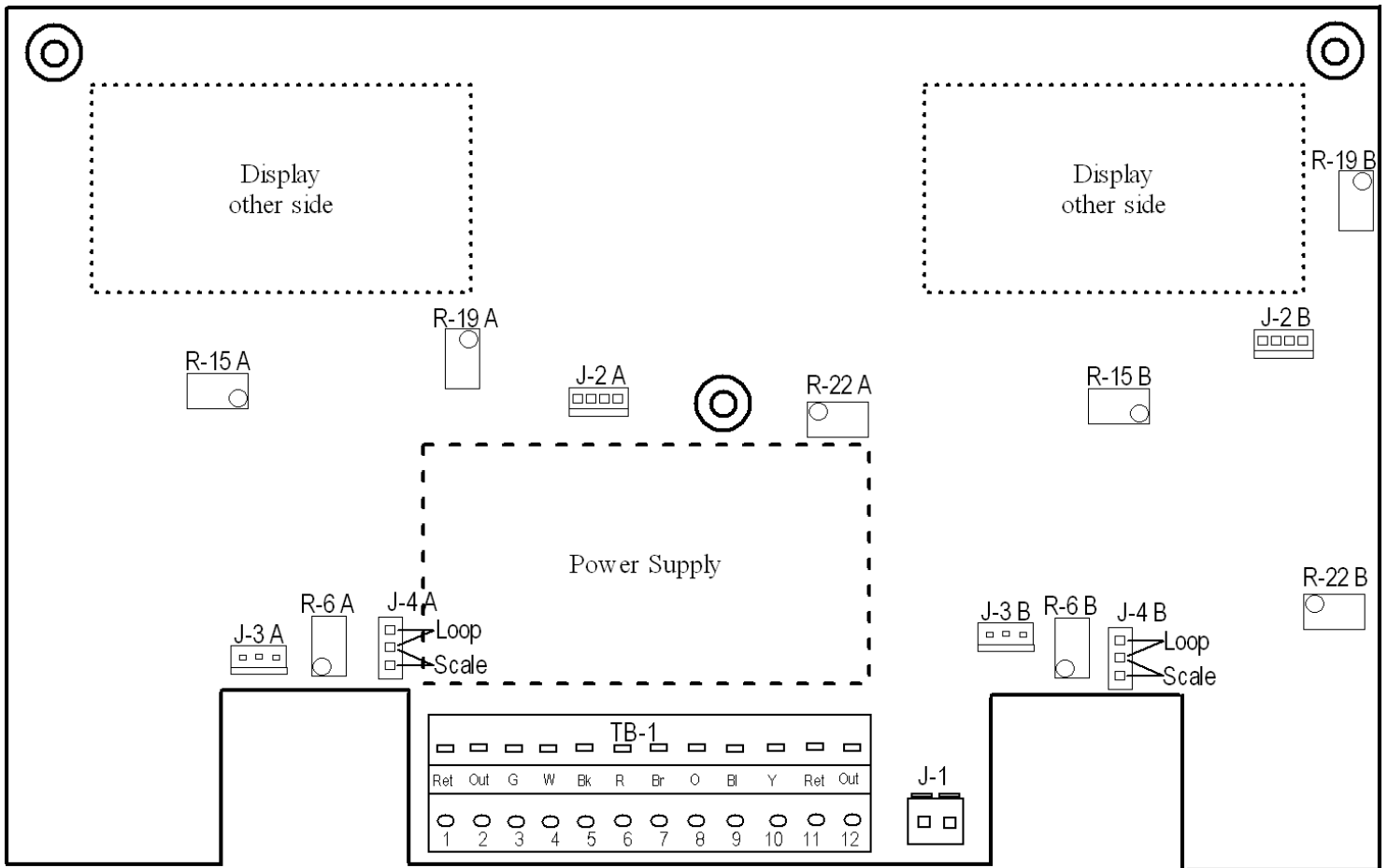

- TB-1 Connections**
- Ret = 4-20 mA Return
 - Out = 4-20 mA Output
 - G = Green = + Signal
 - W = White = - Signal
 - Bk = Black = - Supply Voltage
 - R = Red = + Supply Voltage
 - Br = Brown = - Supply Voltage
 - O = Orange = + Supply Voltage
 - Bl = Blue = + Signal
 - Y = Yellow = - Signal
 - Ret = 4-20 mA Return
 - Out = 4-20 mA Output
- #S 1-6 to Right Display
 #S 7- 12 to Left Display
- J-1 = AC Power Connection
 - J-2 A & B = Low Level (optional) Connection
 - J-3 A & B = Tare Pot Connection
 - J-4 A & B = Scale or Loop Powered 4-20mA selection:
 Jumper on top two pins = Loop powered, Jumper on bottom two pins = Scale powered
 - R-6 A & B = Tare Span Adjustment
 - R-15 A & B = Weight Span Adjustment
 - R-19 A & B = 20 mA Adjustment
 - R-22 A & B = 4 mA Adjustment

4-20 mA Diagram:

Refer to appropriate diagram:

LOOP POWERED DIAGRAM

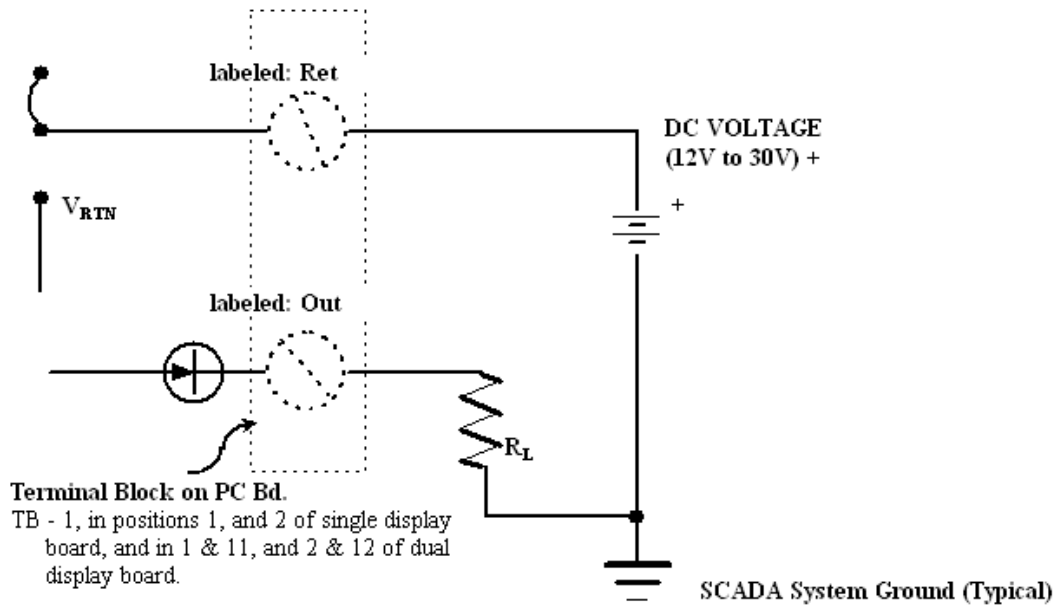

SCALE POWERED DIAGRAM

