



OEM Manual

**MODEL 1020™
5 DIGIT INDICATOR
INSTRUCTION MANUAL**

These instructions generally describe the installation, operation, and maintenance of, subject equipment. The manufacturer reserves the right to make engineering refinements that have not been described herein. Should any questions arise that may not be answered specifically by these instructions, they should be directed to Scaleton Industries Ltd., or our Sales Agent for a response.

All possible precautions were taken in packaging each piece of equipment to prevent shipping damage. *Carefully inspect each item and report damages immediately. Report damage claims to shipping agent involved for equipment shipped F.O.B. job site. Do not install any damaged equipment!*

All instructions given on any labels, or attached tags, should be followed. Carefully inspect all packing material before discarding, to prevent the loss of accessories, mounting hardware, spare parts, or instructions.

TABLE OF CONTENTS		PAGE #
I.	GENERAL DESCRIPTION.....	1
II.	SPECIFICATIONS.....	1 - 2
III.	ASSEMBLY AND START UP INSTRUCTIONS	2 - 4
IV.	GENERAL USAGE: The Operator's Menu.....	5 - 7
V.	SET-UP MENU.....	7 - 11
VI.	TROUBLESHOOTING.....	11 - 12
VII.	WIRING DIAGRAM FOR 4-20 mA HOOK-UP.....	13
VIII.	ORIENTATION DIAGRAMS.....	14 - 15
IX.	BASE INSTALLATION INSTRUCTIONS.....	attached to front of manual

I. General Description:

The Model 1020™ 5 Digit Indicator provides a means for weighing chemicals, controlling the processes of filling, or emptying containers. The Model 1020™ will monitor up to two scale systems while displaying both channels on the backlit, LCD display, simultaneously. There are four available set points available to configure as HI or LO set point that will activate a contact closure. The electronics are housed in a NEMA 4X, UL approved enclosure. The indicator plugs into a wall power source and operates on 120 / 240 VAC, at 50/60 Hz. **The Model 1020™ is recommended for use with all of our drum, tank, platform, and ton cylinder scale bases.**

Standard features

Indicator
Instruction Manual
4-20mA signal (for each active channel)

Available Options

Additional cable lengths as specified
Set Points: a maximum of four available

II. Specifications:

Channel: 1 – 2 Independent weighing channels with independent input / output controls

Input: up to (16) 350 Ohm load cells, total, on indicator

Display Units: pounds, kilograms, gallons, and liters

Range: Maximum Reading: 99,999

LCD Display: alphanumeric display, 2 lines of 16 characters, backlit for easy reading

Keyboard: 3 Function keys

Connector: Power cable sealed with plastic strain relief

Enclosure: NEMA 4X, UL Approved Enclosure

Performance: Overall system accuracy 0.1% to 0.25% Full Scale

Power Rating:

Voltage: 120 / 240 VAC

Frequency: 50/60 Hz

Power: 0.10 / 0.05 A

MAINS Supply Operational Range: +/- 10% of Nominal VAC

Operational Temperature: 0 C - 40 C

Maximum Rated Altitude: 2000 m

Maximum Relative Humidity: 20% to 90% non-condensing

Pollution degree: 2

Weight of Indicator: approximately 7 lbs.

Dimensions of Indicator: 11.31" high, 9.31" wide, 5.43" deep

Recommended Indicator Location: This indicator should be located in a location that protects the indicator from being soaked with liquids or extreme weather locations. If the indicator is to be located outdoors, you must make sure not to exceed the operational temperature range, and it is recommended that you provide a covering to protect the indicator from the elements. Locations inside buildings should be at a height that protects it from chemical splashes and wash-down areas, but still allow for easy operation of keypad.

Please note: It is imperative that you read the instructions in the manual. Indicator is fully tested and programmed to the corresponding base at the factory. If you experience a problem with this equipment, please disconnect all accessories to this equipment to isolate the problem. As we have taken great care to be sure your equipment is fully functional within factory specifications before it leaves our facility, it is best to familiarize yourself with the manual for set-up and operation procedures before you begin using this equipment. All safety precautions need to be observed for the safe operation of this equipment. Failure to operate this equipment as instructed can result in damage to the equipment, and can possibly cause injury. Damage caused to equipment due to improper operation will not be considered for warranty coverage.

III. Assembly and Start-up Instructions:

Before you begin, please notice the programming sheet that comes in the box with your indicator and instructions. This page tells you the parameters to which your unit has been programmed. Your unit is programmed at the factory as it is ordered. If there are incorrect parameters, please refer to this manual to see how any changes you make will affect the other options, and the calibration of your unit. It is imperative that you correctly set the menus in order for this unit to work. Any changes in the units, decimals, count-by, resolution, and calibration of the unit will affect the output! If you make any changes to the set-up, you must record the menus you alter so that you can inform customer assistance if you call for technical help. Without the changes, our factory will be trying to advise you using the factory set-up!

Indicator Precautions:

The indicator is sent with a door latch, and the door will have two screws holding the door shut. Those screws are to be removed in order to insert the connections to the various connectors in the box. When connections are complete, and the indicator door is latched closed, you must reinstall the screws that hold the indicator door closed. The power cord is attached at the factory using a liquid tight fitting. Do not modify or restrict the ability to disconnect the power cord from the outlet. Connections for bases using other fittings or conduit must be made in the field. Please take care to not damage the internal components when drilling a hole in the indicator box. All holes drilled MUST be sealed so that gasses and liquids cannot penetrate the box and damage the internal electronics. Do not drill holes where the internal cables are located. If there is a gap or opening in the box that isn't sealed by the connector, use a silicon caulk to seal the opening from exposure. Please use fittings that are liquid tight fittings and are rated for NEMA 4X conditions. Do not use any type of conduit fitting or other fittings that do not have a tight seal to the indicator. Damage may occur if gasses and liquids have access to the electronics! The mounting location of the indicator should be at operational level, away from the floor. Indicator is a NEMA 4X rated enclosure; however, it is not designed to withstand wash-down procedures, or chemical contact beyond accidental exposure. Please choose a location that will protect the indicator from direct contact with chemicals, or regular soaking of water. Indicator is mounted to wall using the four holes in the tabs on the indicator box.

If the indicator is mounted in a way that does not comply to the standards above, the resulting damage will not be considered for warranty repair, and may cause substantial damage to the electronics.

If the indicator should require cleaning, a cloth damp with water would be recommended to wipe the display and keypad area, as long as the chemical conditions can allow for it. Due to the fact that the chemical environment in which the 1020™ may be located, can vary greatly, we cannot identify one specific cleaner to maintain the indicator. You must use your own discretion when cleaning with any substances. Mild cleaners should not affect the indicator box. Harsh or abrasive cleaners are NOT recommended for use as they may etch or scratch the finish on the mylar or enclosure.

Before making connections, it is wise to plug the indicator into a power source to confirm that the indicator is in working order. If the indicator is functioning properly, you will see the LCD display flash a Model number and version number, and then after a few seconds, it will proceed to the Net Weight screen. If one channel is active, the screen will display:

#1 _ _ _ _ _ 0 _ (Units).

With two active channels, the display will show:

#1 _ _ _ _ _ 0 _ (Units)

#2 _ _ _ _ _ 0 _ (Units)

Please disconnect the power before making all internal wiring connections!

In order to start the Model 1020™ 5 Digit Indicator, you must first install the bases according to their instructions. Please refer to the Base Installation portion of the Instruction Manual found on the last page of the manual, for the safe and correct installation of your new base(s). The Orientation Diagram on page 10 will illustrate the layout of the area on the interface board where the wires need to be connected. If a “Remote Box” option is ordered, there will be instructions included for the wire connections at the remote box, and then to the Model 1020™.

After bases are secured, according to factory instructions, connect them to the indicator as shown on Diagram 1. **TB1** is the connection location for Channel #1. If more than one channel has been ordered, the connections are as follows: **TB2** is the connection location for Channel #2. The wire color code is as follows: R = red, G = green, W = white, B = black, and S = shield (referring to the wires that come from the base to the indicator). The terminal blocks are labeled with the letters to guide you.

4-20mA Connection:

The 4-20 circuit for the Model 1099™ is a LOOP POWERED circuit, or supplied or externally supplied with power. The circuit is designed to work with a supply range of 18-30 VDC, but the nominal supply rating is 24 VDC.

The 4-20mA signal connections are located at the connectors labeled: **TB9**, (and if optional, second, 4-20mA connection is ordered) **TB10**. The connectors are labeled with positive and negative respectively. **TB9** is the connection site for 4-20mA reading at Channel #1, **TB10** is the connection site for Channel #2.

Please refer to the 4-20mA connection diagram, on page 14, for proper connection of wires.

Set Point Connections:

The Model 1099™ has an option for up to set point circuits with a relay rated for 5 VDC, 40mA, and coil resistance of 125 Ohms. Relays are SPST-NO + SPST-NC.

The Set Point connections, if ordered as an option, are located at the connectors labeled: **TB5**, **TB6**, **TB7**, and **TB8**. **TB5** is the connection site for the set point option for Set Point #1. **TB6** is the connection site for Set Point #2, **TB7** is the connection site for Set Point #3, and **TB8** is the connection site for Set Point #4.

Now you are ready to plug the Model 1020™ indicator into the wall power supply source.

IV. General Usage:

The Operator's Menu:

The Model 1020™ has a three button keypad that allows the user to navigate the operator's menu. There is a Select key * and an up and down arrow keys ▲ ▼ that are used to select, or scroll, respectively. The arrow keys can be pushed and held to scroll. The longer the button is held, the faster the numbers will scroll. The unit is shipped from the factory fully calibrated and configured to the specifications on the purchase order, but values for 4-20mA are easily changed in the set up mode. Bases and indicators are matched and calibrated to a specific channel to provide the highest level of accuracy. After connections have been completed and the base installation and optional equipment is connected, please refer to the following procedure for start up and general use directions.

To begin, determine your method of use. Will you load a full container on the scale base, or will you be filling an empty container and using product? Choose the proper method of use section and following the instructions.

Load Tank Method:

When using the method of loading full containers onto the scale frame, you should use the following procedure.

Apply power to the indicator by plugging the indicator into a wall power source. When indicator is in start-up, it will flash a display that shows the Model number and the version of software. The indicator will then display the active channels in the format of NET WEIGHT. One channel will be displayed if that is the only one active, or if two are active, each line will display a net weight reading.

To begin, press the select key * to see channel #1 with a bar graph display

depicting a graphic representation of full scale. Pressing select * again will display channel #2 with a bar graph display depicting a graphical representation of full scale (if second channel is active).

Press the select key * again to see the "Tare Adjust" screen for the channel #1. If there is any residual weight displayed on the screen, begin by adjusting the arrow key to see zero.

If you know the tare weight of the container you will be placing on the base,

©2011 Scaleton Industries Ltd., Plumsteadville, PA Scaleton, Scaleton Sets the Standard In Corrosion Resistance, Model 1020-1, 1020-2, Model 1099, Model 2305, Model 2306, Model 2307, Model 2308, Model 2310, Model 2330, Model 2350, Model 2352, Model 2353, Model 3001, Model 3002, Model 3003, Model 3004, Model 3005, Model 3006, Model 3050-1, Model 3050-2, Model 4000SS, Model 4010, Model 4020, Model 4021, Model 4030, Model 4040, Model 4040IBC, Model 4041, Model 4042, Model 4042WB, are trademarks of Scaleton Industries Ltd. Total Electronic System is a service mark of Scaleton Industries Ltd.

follow this procedure:

From the screen that says: #1 _ _ _ _ _ 0 _ (units) (Net), TARE ADJUST
 You will use the arrow keys to set the screen to read in the negative, the amount of tare weight you will apply to the scale. This may include any other equipment in addition to the empty container weight. Set the weight using the arrow keys to read that number negative, and then load the container onto the scale. Press the

select key * and repeat the procedure for the second channel if active.

Press the Select key again * to see the gross weight screen. This will be the tare weight you adjusted PLUS the net weight. One or two channels may be

displayed. Press Select * again to return to the net weight screen.

Procedure is complete. Repeat as you change containers.

If you are loading containers when the tare weight is not known, or if you prefer to use a known net weight, follow this procedure:

From the Net Weight Screen, Press Select * key to see the channel #1 Net

Weight screen with bar graph. If second channel is active, Press Select * key to see the channel #2 Net Weight screen with bar graph (of if not active, menu

will continue as follows). Press Select * key to see the TARE ADJUST screen.

Place the container onto the scale base and adjust the net weight showing on the screen to the correct amount. Use the down arrow to reduce the weight to that

proper net weight amount. Press Select * key again to adjust the second

channel if active. Press Select * once more to see the Gross Weight screen.

Press Select * one more time to return to the Net Weight display.

The following procedure is for applications where a container will remain on a scale base and be filled and emptied.***Fill Tank:***

When operating in Fill Tank Mode, it is imperative that this procedure is followed to assure proper readings of the weight.

For use the FIRST time, user should place the scale into its permanent position,

level the scale, and connect all wires according to the base installation instructions. Once scale base is properly installed and the empty tank is loaded, the scale should be zeroed. This is accomplished by the following: From the

NET WEIGHT (main screen), press Select key * one time to see channel #1 with a bar graph display depicting a graphic representation of full scale. Pressing

select * again will display channel #2 with a bar graph display depicting a graphical representation of full scale (if second channel is active). Pressing select

* again will advance to the #1 _ _ _ _ _ 0 _ (units), ▲ ▼ TARE ADJUST screen. With the empty container and any equipment that will apply weight to the scale frame properly installed, use the arrow keys to adjust the Net Weight reading to zero. Proceed to fill the container.

DO NOT ADJUST THE NET WEIGHT AMOUNT AGAIN unless container is removed and a new, empty container will be used. From this screen, press the

select key * one more time to see the second channel, if active, or the Gross

Weight screen. Press * once again from second channel to Gross Weight screen. Pressing select again will return you to the Net Weight Display. When you are ready to re-fill the tank, you will not be required to adjust anything, as you will need to account for residual chemical left in the container. Just simply fill and use contents. If the container is replaced, you will repeat this procedure from the beginning.

V. Set-Up Menu:

This menu should only be entered if there is a requirement to reset the factory calibration, or adjusting set points. Changing other settings will modify the calibration of the scale and will make the indicator appear to have “lost” calibration. Do not alter any settings unless you are sure that what you are changing is necessary!

In order to view this menu, you will need to place the jumper as seen on the orientation diagram of the display board, in the position JP1 (located at the bottom of the display board) in the position of the two pins to the left, closest to the “A” on the board. Display automatically will show “▲▼ SETPOINT SETUP [*]” screen. You are now in the SetUp Menu.

A. The LCD will read, **SETPOINT SETUP [*]**.

Press the Select Key to enter this menu. Screen will say: SETPNT #1 SOURCE \blacktriangle \blacktriangledown SCALE1 [*]. You may choose to alter this set point to have a different source by using the arrow keys. If you have a second active channel, you may apply the set point to the second channel. The screen will now read: SETPNT #1 VALUE, \blacktriangle \blacktriangledown _ _ _ _ X_ [*]. (X Represents the set point value.) Use the arrow keys to adjust the value of the set point. Press the select key to advance to the next screen. The screen will now read: SETPNT #1 TYPE, \blacktriangle \blacktriangledown NONE.

Pressing the arrow keys changes the status of the set point. The options are Hi, Lo, or None. Press Select to choose a type. [*] The next screen will advance to the choices for Set point #2, and on through four, regardless of what has been activated on the scale. Setting the set points to None is a way to indicate that they are not active.

Press [*] until display reads "SETPOINT SETUP [*]".

Press an Arrow key \blacktriangle \blacktriangledown again to move to the next option.

B. The LCD will read: \blacktriangle \blacktriangledown _ _ _ _ _ UNITS _ _ [*].

Press the Select Key to enter this menu. The screen will say: UNITS _ _ _ _ \blacktriangle \blacktriangledown LBS _ _ _ [*]. Use the arrow keys to select from LBS, KG, GAL, LTR. Press the Select Key [*] to choose the units. Press Arrow key \blacktriangle \blacktriangledown again to move to the next option.

C. The LCD will read: \blacktriangle \blacktriangledown _ _ _ _ _ DECIMAL PLACES _ _ [*]. Press the Select key [*] to enter this menu. Press the arrow keys \blacktriangle \blacktriangledown choose an option: None, or XXXX.X (tenths). Press Select key [*] to choose the setting and leave the menu. Press \blacktriangle \blacktriangledown arrow keys to advance to the next menu option.

D. The LCD will read: \blacktriangle \blacktriangledown _ _ _ _ _ FIXED ZEROS _ _ [*]. Press the Select key [*] to enter this menu. Press the arrow keys \blacktriangle \blacktriangledown choose an option: None or 1 _ _ (XXXXX0) _ _ [*]. Press the Select key [*] to choose an option and leave this menu. Press \blacktriangle \blacktriangledown arrow keys to advance to the next menu option.

- E. The LCD will read: $\blacktriangle\blacktriangledown$ _ _ _ _ _ **COUNT BY** _ _ [*]. Press the Select key [*] to enter this menu. Press the arrow keys $\blacktriangle\blacktriangledown$ choose an option: 1, 2, OR 5. Press the Select key [*] to choose an option and leave this menu. Press $\blacktriangle\blacktriangledown$ arrow keys to advance to the next menu option.
- F. The LCD will read: $\blacktriangle\blacktriangledown$ _ _ _ _ _ **RESOLUTION** _ _ [*]. Press the Select key [*] to enter this menu. The LCD will show: SCALE1 RESOLUT'N $\blacktriangle\blacktriangledown$ _ _ _ _ _ xxxxx _ _ [*]. Press the arrow keys $\blacktriangle\blacktriangledown$ choose an option: 32000, 16000, 12000, 8000, 4000, 3000, 2000, 1000. Repeat this procedure for the second channel. Press the Select key [*] to choose an option and leave this menu. Press $\blacktriangle\blacktriangledown$ arrow keys to advance to the next menu option.
- G. The LCD will read: $\blacktriangle\blacktriangledown$ _ _ _ _ _ **DENSITY** _ _ [*]. Press the Select key [*] to enter this menu. The LCD will show: **SPEC. GRAVITY #1** = _ **X.XXX** _ _ _ _ _ [*]. Press $\blacktriangle\blacktriangledown$ arrow keys to adjust the specific gravity for the channel listed. Press the Select key [*] to advance to the next option, and set the specific gravity for channel #2: **SPEC. GRAVITY #2** = _ **X.XXX** _ _ _ _ _ [*]. Press $\blacktriangle\blacktriangledown$ arrow keys to adjust the specific gravity for the channel listed. Press the Select key [*] to complete this menu and press $\blacktriangle\blacktriangledown$ arrow keys to advance to the next menu option.
- H. The LCD will read: $\blacktriangle\blacktriangledown$ _ _ _ _ _ **4-20 MA SETUP** _ _ [*]. Press the Select key [*] to enter this menu. Display will show: **4-20 MA RANGE #1** $\blacktriangle\blacktriangledown$ _ _ XXXXX _ _ [*]. Press the arrow keys $\blacktriangle\blacktriangledown$ to adjust the number value for the proper 4-20mA setting for channel #1. Press the Select key [*] to choose an option and proceed to the setting for channel #2. : **4-20 MA RANGE #2** $\blacktriangle\blacktriangledown$ _ _ XXXXX _ _ [*]. Press $\blacktriangle\blacktriangledown$ arrow keys to set this range. Press the Select key [*] to complete this menu and press $\blacktriangle\blacktriangledown$ arrow keys to advance to the next menu option.

- I. The LCD will read: $\blacktriangle\blacktriangledown$ _ _ _ _ **CALIBRATION** _ _ [*]. Press the Select key [*] to enter this menu. The LCD will show: SCALE TO CAL. $\blacktriangle\blacktriangledown$ 1 _ _ _ _ [*]. Press the Select key [*] to continue with calibration. LCD will show: REMOVE WEIGHT AND PRESS [*]. Screen will show "PLEASE WAIT...." While it stores this value. ***It is crucial that you do not move any weight on the scale base at this point. The unit is storing the values it is sampling!*** Screen will automatically advance to the next screen: LOAD CAL. WEIGHT AND PRESS [*]. At this time you must load the calibration weight which must exceed 20% of the resolution for that channel. Press the Select key [*]. Screen shows: CALIBRATION WT. $\blacktriangle\blacktriangledown$ _ _ _ _ _ 0 _ _ _ [*]. Use the arrow keys $\blacktriangle\blacktriangledown$ to adjust the calibration weight amount. It is the gross weight that you load onto the base. (If the amount you are using is less than 20%, you will see the following message: WEIGHT TOO LOW: 20% MIN. _ _ _ [*]. Pressing the select key will return you to the CALIBRATION WT. screen. You may add weight to the scale and re-try.) (If you have the proper weight, the screen will proceed). PLEASE WAIT.... will temporarily appear on the screen. When complete, the screen will display: CALIBRATION DONE (XXXXX) _ _ _ _ [*]. Press the Select key [*] to leave this menu. Repeat this procedure for the second channel if needed. Press $\blacktriangle\blacktriangledown$ arrow keys to advance to the next menu option.
- J. The LCD will read: $\blacktriangle\blacktriangledown$ _ _ _ _ _ _ **AVERAGE BY** _ _ [*]. Press the Select key [*] to enter this menu. Press the arrow keys $\blacktriangle\blacktriangledown$ choose an option: Standard (which is 10), 100 READINGS, 50 READINGS, or 20 READINGS. (Choosing a higher number increases the number of samples the scale will average before displaying a change in rate. This helps to remove small fluctuations in readings due to vibrations of nearby equipment.) Press Select key [*] to choose the setting and leave the menu. Press $\blacktriangle\blacktriangledown$ arrow keys to advance to the next menu option.
- K. The LCD will read: $\blacktriangle\blacktriangledown$ _ _ _ _ _ _ **BARGRAPH** _ _ _ _ _
 _ _ _ **FULL SCALE** _ _ [*]. Press the Select key [*]. The Display will now read: FULL SCALE _ _ _ _ _ #1, $\blacktriangle\blacktriangledown$ _ _ _ _ _ 1.000 _ _ _ _ [*]. Adjust the value, using the arrow keys to reflect the value which is full scale for

the Net Weight. Press the Select key [*]. Assuming that second channel is active, the Display will now read: FULL SCALE _ _ _ _ #2, ▲▼
_ _ _ _ 1.000 _ _ _ _ [*]. Adjust the value to reflect the value which is full scale for the Net Weight of channel #2. Press the Select key [*].

- L. The LCD will read: ▲▼ VERSION: X.X.X SOURCE: xXXXXXX. This screen will provide you with information to provide the factory if assistance is needed. Use the arrow keys to go to the next menu option.

With NO jumper installed in location JP3 on Display board, the next menu option will read:

[RESERVED FOR FUTURE USE]

With a jumper in location JP3 on the Display board, the display will show:

- M. The LCD will read: ▲▼ RESTORE FCTY CALIBRATION [*]. Press the Select key [*] to see: ARE YOU SURE? ▲▼ = NO, [*] = YES. If you wish to restore factory calibration, press the Select key. Screen will show: RESTORE DONE _ _ _ [*]. Press the select key again to return to beginning of menu. If you wish to abort the attempt to restore calibration, then press an arrow key instead.

Pressing an arrow key from prior screen returns you to the first menu option. To leave the SET-UP MENU area, remove the jumper on JP1 from the A position, and move it to the right two pins, (“B”) position. This will instantly return you to the OPERATOR’S MENU.

- V. **Troubleshooting:** Please DO NOT ATTEMPT TO ALTER OR RE-CALIBRATE THIS INSTRUMENT ON YOUR OWN UNLESS INSTRUCTED TO DO SO. IT HAS BEEN CALIBRATED AND TESTED BEFORE IT LEAVES THE FACTORY. Should you experience trouble, please read the following for easy diagnosis, and then call the factory for assistance.

If “88888” appears for net weight: This is a condition of overload in weight. The most likely cause is that the weight on the scale exceeds the net weight that was configured for the base. Go through each step in the Set-up menu to verify that chosen options are correct.

If indicator is not receiving any power: DO NOT, AT ANY TIME, STICK ANYTHING INTO THE OPEN FRAME POWER SUPPLY OR TOUCH THE COMPONENTS! YOU CAN RECEIVE A SHOCK!!!! Check outlet for power. Check to see that scale is plugged into an outlet with the proper voltage. Check

the small green light on the power supply board (on the top right corner of the Interface board in the back of the indicator box) to make sure it is lit (not blinking). If the light is completely out, or blinking, the problem exists in something **before** the power supply, or something is placing the power supply in “current overload”. Try disconnecting power, and removing all other equipment other than the scale base wires and the power cord (this means 4-20 equipment and relay connections). Plug unit back into power to see if this fixes the situation. If it does, the problem is not with the 1020™. Check the 4-20mA hook-up to be sure that the power supply to the 4-20 circuit is within the correct range. Reconnect one piece at a time to isolate the problem. The power supply’s safety shut down will cause it to beep and blink the green light. If this starts to happen, remove power quickly and fix problem. If problem persists, call the factory about the problem and describe the condition to a technical advisor.

If the 4-20mA reading is incorrect: This 4-20 circuit is Loop powered, so a supply of power of 18-30 VDC must power the 1020™. Please refer to the diagram on page 10. Check to make sure the wire insulation is not pinched in the connector. Wires should stay in the connector even if you **gently** tug on the wires. Insert the wire so that it makes good connection. Check to make sure the scale has been configured properly in the SET-UP Menu. If the problem persists, please take note if you have a reading of 4mA or 20mA without changing regardless of weight, or if there is a reading of 0 mA. This will be important in diagnosing problem.

If the level indicating relay is not working: check to make sure the wire insulation is not pinched in the connector. Make sure the indicator is programmed properly in the *Set-up menu*. Check the setting of a HI or LO set point to see if relay is configured to act properly. Relay will be NO or NC depending on connection. Please refer to Orientation Diagram for relay connections. If problem persists, call the factory.

If problems persist, **PLEASE CALL THE FACTORY!** If in the U.S.A., call: 1 (800) 257-5911. Outside of the U.S.A. (215) 766-2670.

VI. Wiring Diagram for 4-20 mA connection:

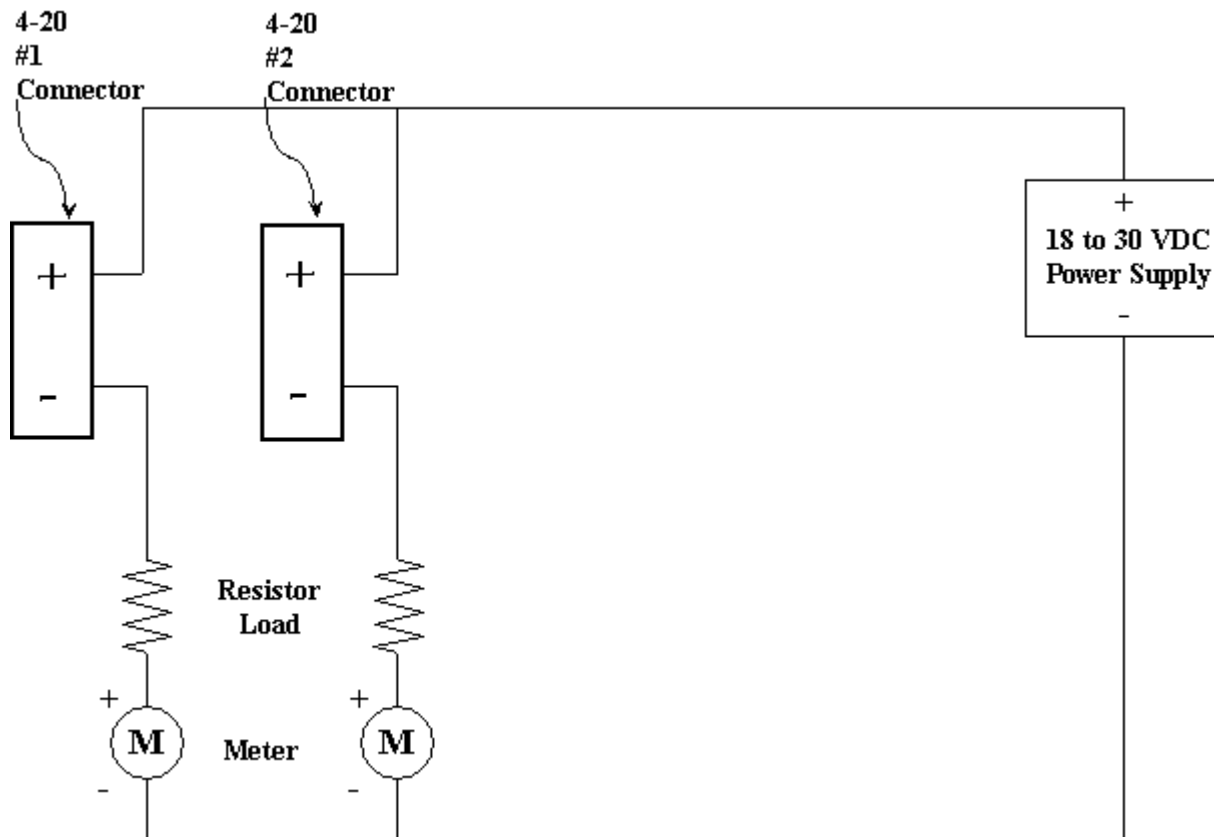

Please note that the power supply in this diagram can range in output from 18 to 30 VDC to supply power to the loop powered 4-20mA circuit. Typical supplies are around 24 VDC. If you have any questions regarding the connections of this unit, please notify the factory.

VII. Orientation Diagrams:

5 Digit Display Board

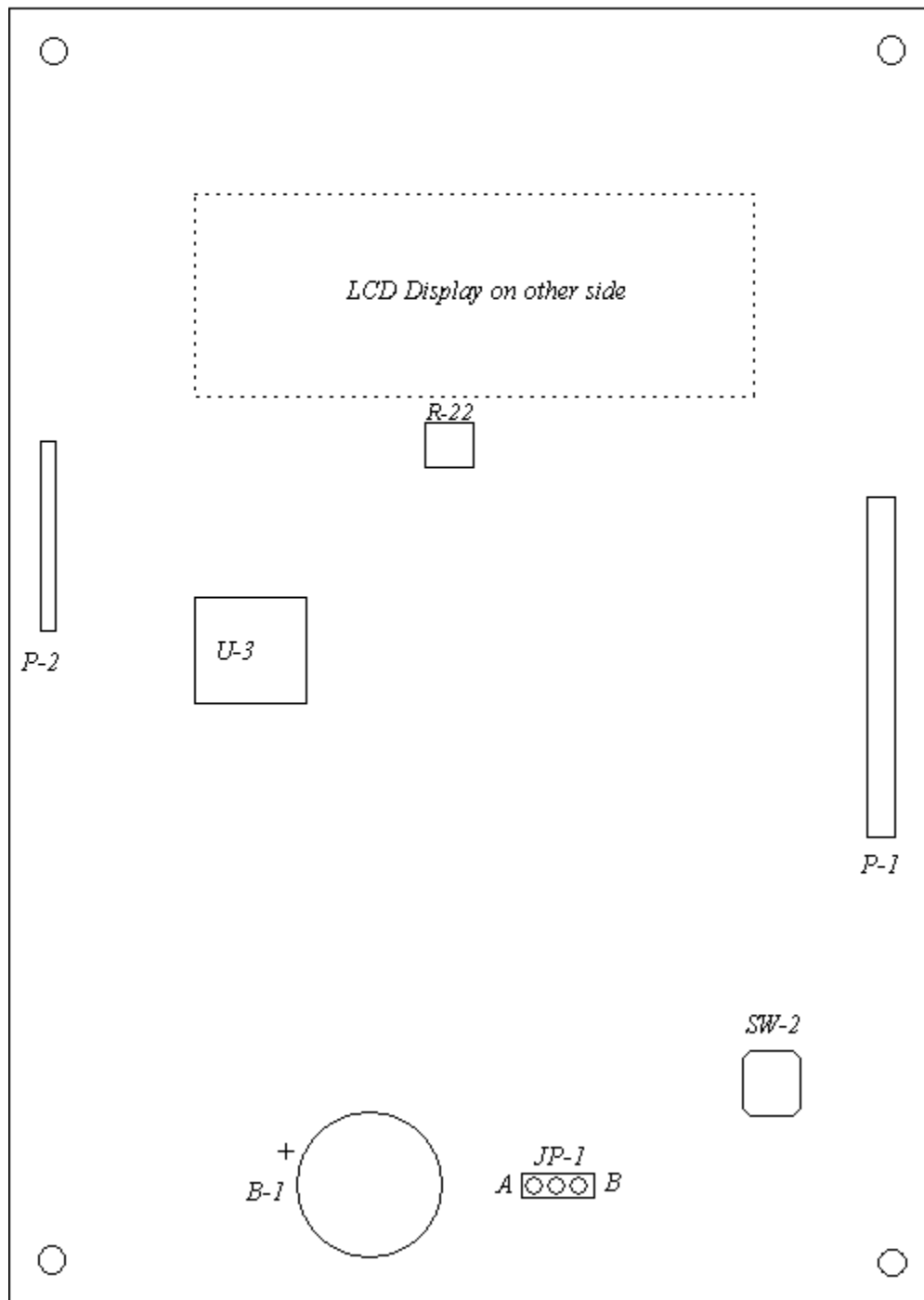

©2011 Scaleton Industries Ltd., Plumsteadville, PA Scaleton, Scaleton Sets the Standard In Corrosion Resistance, Model 1020-1, 1020-2, Model 1099, Model 2305, Model 2306, Model 2307, Model 2308, Model 2310, Model 2330, Model 2350, Model 2352, Model 2353, Model 3001, Model 3002, Model 3003, Model 3004, Model 3005, Model 3006, Model 3050-1, Model 3050-2, Model 4000SS, Model 4010, Model 4020, Model 4021, Model 4030, Model 4040, Model 4040IBC, Model 4041, Model 4042, Model 4042WB, are trademarks of Scaleton Industries Ltd. Total Electronic System is a service mark of Scaleton Industries Ltd.

Model 1020™- 5 Digit Indicator Interface Board Orientation Diagram

