



# R900 RF

WALL OR PIT MIU



The R900® MIU provides water utilities with a reliable and economical RF reading solution.

**PIT VERSION**

**WALL VERSION**

The R900 Meter Interface Unit (MIU) is a compact electronic device that collects meter-usage data from up to two networked encoder registers and transmits the data for collection by the meter reader. The R900 MIU is compatible with ARB® III, IV & V, ProRead (ARB VI), E-Coder™ (ARB VII), and Sensus ECR® II & III\* encoder registers. The R900 MIU automatically detects the type of register to which it is connected; therefore, no field programming is necessary.

Data transmitted by the MIU is received by Neptune walk-by, mobile, or fixed-network data collection systems and stored for downloading at the utility office. The R900 MIU is a one-way communication device that transmits data using frequency hopping spread-spectrum technology to ensure data security and improve meter reading accuracy and reliability.

When connected to a single encoder register by a three-conductor wire, the R900 MIU reads the register automatically once an hour and transmits the meter reading with MIU ID number every 14 seconds. When connected to two networked encoder registers, the R900 MIU reads the registers automatically once an hour and transmits the meter readings with MIU ID numbers alternately every 11 seconds. When connected to E-Coder electronic absolute

encoders, the R900 MIU reads the registers every 15 minutes and transmits in the same intervals as described.

As part of the ARB “absolute” encoder technology, the remote electronic reading is guaranteed to match the reading on the encoder register exactly (once per hour) when the R900 MIU interrogates the encoder register.

**R900 WALL MIU**

The R900 Wall MIU features a compact enclosure that can be easily mounted to most flat wall surfaces or pipe. The R900 Wall MIU can be installed as far as 500 feet from the encoder register. The MIU is designed to easily upgrade existing probe-based systems that use wall receptacles.

**R900 PIT MIU**

The R900 Pit MIU features a compact enclosure equipped with an external antenna for optimal performance. The antenna is designed to be mounted above the pit lid through the industry standard 1-3/4” hole. The rugged antenna design allows installation in high traffic areas and the electronic enclosure is fully potted to withstand flooded pit environments. The MIU is designed to easily upgrade probe-based systems that use pit receptacles.

**KEY FEATURES**

- No FCC license required
- No MIU programming required - automatically detects register type
- Long-life lithium battery with HLC capacitor
- Available in both a wall and a pit version
- Fully submersible pit enclosure
- Rugged pit antenna designed to withstand traffic
- Reads up to two networked ProRead or E-Coder™ encoder registers
- Compatible Neptune meter reading systems
- Enables E-Coder “value-added” features\*
- Suitable for any size utility
- 20-year warranty (10 full/10 prorated)

\* When connected to second generation or later R900.

\* The ECR® III Register is supported when programmed with the same format used in the “6 wheel ECR II register.”

**DIMENSIONS**

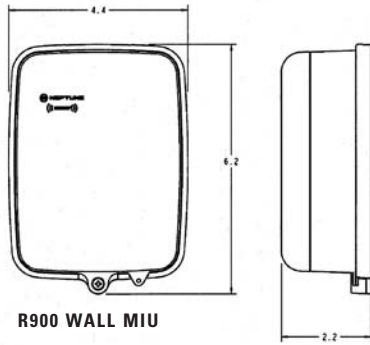

**R900 WALL MIU**

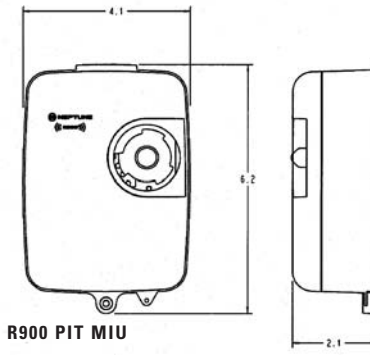

**R900 PIT MIU**

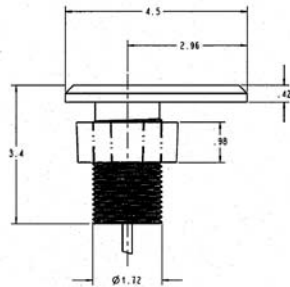

**R900 PIT ANTENNA**



The R900 works with route management software to provide a complete meter reading solution with advanced functions for water utilities.

**KEY BENEFITS**

- Enhanced output power allows migration from walk-by to mobile, and fixed-network for targeted C&I accounts
- Provides value-added features like leak, tamper and reverse flow detection when connected to Neptune's E-Coder electronic absolute encoder\*
- Improves meter reading accuracy
- Addresses "hard-to-read" meters
- Increases meter reader safety
- Minimizes reading time
- Enhances customer care
- Reduces costs
- Easy to install
- Easily upgradeable with existing probe-based systems

**TECHNICAL SPECIFICATIONS**

- Electrical Specifications:
  - Power: Lithium battery with HLC capacitor
- Transmitter Specifications:
  - Transmit period: Every 14 seconds for single meter and alternately every 11 seconds for two networked encoder registers
  - Transmitter channels: 50
  - Channel frequency: 910 to 920 MHz spread spectrum
  - Output Power: Meets FCC Part 15.247
  - FCC Verification: Part 15.247
- Encoder Register Interface - Wall:
  - Compatible with Neptune ARB® III, IV & V, ProRead and E-Coder™, and Sensus ECR® II & III\*
  - Maximum cable length: Networked - 250 feet (91 m) (total for both registers); Single Register - 500 feet (152 m)
- Encoder Register Interface - Pit:
  - Compatible with Neptune ARB® III, IV & V, ProRead and E-Coder™, and Sensus ECR® II & III\*
  - Two available wire lengths: 6 feet and 25 feet
- Environmental Conditions:
  - Operating temperature: -22°F to 149°F (-30°C to 65°C)
  - Storage temperature: -40°F to 158°F (-40°C to 70°C)
  - Operating humidity: 0 to 95% non-condensing
- Functional Specifications:
  - 1-2 register readings
  - 1-2 MIU IDs

\* The ECR® III Register is supported when programmed with the same format used in the "6 wheel ECR II register."

\* When connected to second generation or later R900.

**Neptune Technology Group Inc.**

1600 Alabama Highway 229  
Tallahassee, AL 36078  
USA  
Tel: (800) 645-1892  
Fax: (334) 283-7299

**Neptune Technology Group (Canada) Ltd.**

7275 West Credit Avenue  
Mississauga, Ontario  
L5N 5M9  
Canada  
Tel: (905) 858-4211  
Fax: (905) 858-0428

**Neptune Technology Group Inc.**

Ejército Nacional No. 418  
Piso 12, Desp. 1201-1202  
Col. Chapultepec Morales  
Delegación Miguel Hidalgo  
11570 México, Distrito Federal  
Tel: (525) 55203 5294 / (525) 55203 5708  
Fax: (525) 55203 6503



neptunetg.com