

AMERICAN AVK RESILIENT SEATED GATE VALVE, 200 PSI 25/00X

To AWWA C509, UL / ULC, & FM Approved (NRS)
Mechanical Joint Post Indicator,
Valve Sizes 4" through 12"

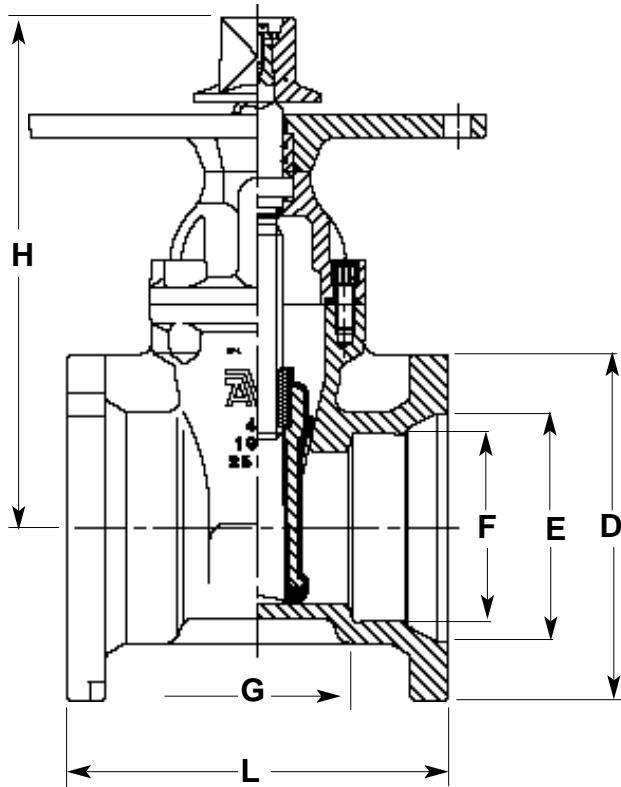

Tests:

Hydraulic test to AWWA C509
Shell test: 500 PSI
Seat test: 250 PSI
Operating torque test

Standard Materials:

Body, Bonnet	Cast iron ASTM A126 class B
Post Indicator	
Plate	
Coating	Electrostatically applied fusion-bonded epoxy-resin meets or exceeds AWWA C550.
Wrench nut	Cast iron ASTM A126 class B - painted black for clockwise closing, red for counterclockwise closing.
Stem	Standard: Low Zinc Bronze ASTM copper alloy no. C99500
Wedge	Ductile iron ASTM A536 vulcanized with EPDM-rubber compound
Stem seal box, Wedge nut	ASTM copper alloy no. C35330
Bonnet Bolts	ASTM A164 zinc coated steel sealed with hot melt.
Gland Bolts	ASTM A153 zinc coated steel Hexagon bolt.
Bonnet gasket, Wiper ring, O-ring stem seals, O-ring gland seal	ASTM D2000 Buna "N" nitrile rubber

Optional Materials:

Bonnet bolts	Option a): Stainless Steel -A2- Grade 304 sealed with hot melt.
Gland bolts	Option a): Stainless Steel -A2- Grade 304 Hexagon bolt.

Approvals:

UL Listed
FM Approved
ULC Listed



Utilization: For water and neutral liquids to max. 160° F

Ref. Nos.	Size	D	E	F	G	H	L	Turns to open
25-100-00-001X	4"	9.12"	6.02"	4.90"	5.0"	13.50"	10"	14
25-150-00-001X	6"	11.12"	8.12"	7.00"	6.50"	17.50"	11.50"	21
25-200-00-001X	8"	13.375"	10.27"	9.15"	6.50"	21.50"	11.50"	26
25-250-00-001X	10"	15.69"	12.34"	11.20"	8"	24.75"	13"	32
25-300-00-001X	12"	17.875"	14.44"	13.20"	9"	27.625"	14"	38

X: 0= Open Left 1= Open Right