

AMERICAN AVK RESILIENT SEATED GATE VALVE, 200 PSI

25/46

To AWWA C509, UL / ULC, & FM Approved (OS&Y)
Flanged Flanged Ends to ANSI B 16.1 Class 125
Valve Sizes 2 1/2" through 12"

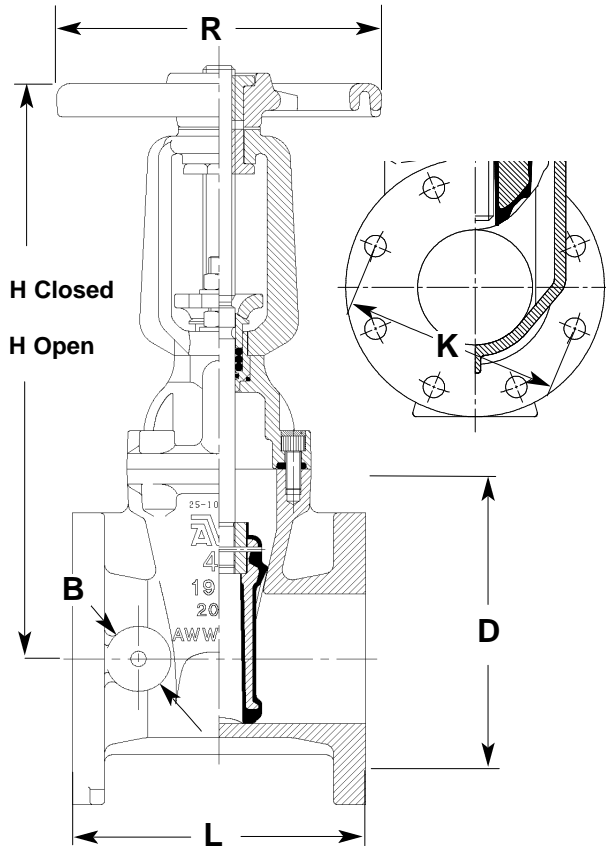

Standard Materials:

Body 2 1/2" to 10" :	Cast iron ASTM A126 class B
12" :	Ductile iron ASTM A536
Bonnet,	Cast iron ASTM A126 class B
Handwheel	
Yoke, Gland follower	Ductile iron ASTM A536
Coating	Fusion bonded epoxy inside and out. Meets or exceeds AWWA C550.
Stem	Bronze,
Handwheel washer,	Bronze
Wedge nut	
2-piece stem nut	
Wedge	Ductile iron core vulcanized inside and out with EPDM - rubber compound.
Bonnet bolts	2 1/2" - 8": Stainless steel, sealed with hot melt 10" and 12": Black coated steel, sealed with hot melt
Stud bolts, washers, Nuts	Zinc coated steel
Bonnet gasket	ASTM D2000 Buna "N" nitrile rubber
O-Rings, Stem seal	
O-Rings	
Stem seal gland,	Akulon
Gland bushing	

Optional Materials:

Bonnet bolts	Option a): Stainless Steel -A2- Grade 304 sealed with hot melt.
Stud bolts, washers, nuts.	Option a): Stainless Steel -A2- Grade 304.

Tests:

Hydraulic test to AWWA C509
Shell test: 500 PSI
Seat test: 250 PSI
Operating torque test

Utilization: For water and neutral liquids to max. 160° F

Approvals:

UL Listed
FM Approved
ULC Listed



Ref. Nos.	Size	B	D	H		L	R	Flange holes	Turns to open
				open	closed				
25-065-46	2.5"	2"	7.0"	15.38"	13.12"	7.5"	9"	4	17
25-080-46	3"	2"	7.50"	16.88"	13.75"	8.0"	9"	4	20
25-100-46	4"	2"	9.0"	20.63"	16.50"	9.0"	11"	8	21
25-150-46	6"	2.50"	11.0"	29.0"	22.88"	10.50"	13"	8	26
25-200-46	8"	2.50"	13.50"	37.12"	29.0"	11.50"	14"	8	35
25-250-46	10"	2.50"	16.0"	44.88"	34.75"	13.0"	18"	12	37
25-300-46	12"	3"	19.0"	51.88"	39.75"	14.0"	18"	12	44