



OEM Manual

MODEL 4040™ - 3 ½ Digit
PLATFORM SCALE

Scaletron™ Industries, Ltd.
Bedminster Industrial Park
53 Apple Tree Lane
P.O. Box 365
Plumsteadville, PA 18949 USA

Toll Free: 1-800-257-5911 (USA & Canada)
Phone: (+1) 215-766-2670 (international)
Fax: (+1) 215-766-2672
E-mail: info@scaletronscales.com
Website: www.scaletronscales.com

These instructions generally describe the installation, operation, and maintenance of subject equipment. The manufacturer reserves the right to make engineering refinements that have not been described herein. Should any questions arise that may not be answered specifically by these instructions, they should be directed to **Scaleton Industries Ltd., Or Our Sales Agent** for a response.

All possible precautions were taken in packaging each piece of equipment to prevent shipping damage. Carefully inspect each item and report damages immediately. Report all damage claims to the shipping agent involved for equipment shipped F.O.B. job site. Do not install any damaged equipment.

All instructions given on any labels, or attached tags, should be followed. Carefully inspect all packing material before discarding to prevent the loss of accessories, mounting hardware, spare parts, or instructions.

<u>TABLE OF CONTENTS</u>	<u>PAGE</u>
I. GENERAL DESCRIPTION.....	1
II. SPECIFICATIONS.....	1 - 2
III. ASSEMBLY AND START-UP.....	2
IV. GENERAL USE INSTRUCTIONS.....	3
V. CALIBRATION PROCEEDURE.....	3 - 4
VI. TROUBLESHOOTING.....	4
VII. BOARD DIAGRAM.....	5 - 6

I. General Description:

The Model 4040™ Platform Scale is designed specifically for regular on and off loading of a tank or drum. Off center loading or solid materials do not affect the scale accuracy due to the four cell design. Mixers and pumps may be used with this base design. Different base sizes are available, as well as custom bases for different size platforms and large capacities. The maximum net weight is 199.9 lb./ or kg. with 0.1 lb/ or kg resolution, or with a maximum net weight exceeding 199.9, the decimal is blanked at the factory, and the display can read 1999 lb/ or kg. on the standard, 3 ½ Digit indicator.

The design of the platform includes sturdy three point support, with a ½” PVC deck. The base is protected from scratches by the PVC decking, and the base is coated with dry polyester powder coating to prevent corrosion. Scale has four NTEP stainless steel temperature compensated strain gauge transducers.

Standard Parts

- | | |
|-----------------|---------------------------|
| 1 Base assembly | 1 Weigh Meter (indicator) |
| 1 Power Cord | 1 Technical Manual |

Available Options

- A. Remote mounting of standard enclosure
- B. Load Cell Cable
- C. Low Level relay contact

II. Specifications:

Display: LCD, 3 ½ Digit with minus sign liquid crystal display, 0.5 inch high, seven segment

Resolution: Tank: 199.9 lb x 0.1 lb, or 200 to 1999 lb.x 1.0 lb.

Load Cell Excitation: 12 VDC Power, 4 Load cells

Zero Adjustment: Internal potentiometer, External tare knob

Overload: Blanks with "1" displayed at the far left of the display

Accuracy: +/- 0.5% full capacity

Power: 85-265VAC ~ 50/60 Hz, single phase, 0.42 Amps Dedicated – Isolated Power With Earth Grounding

Dimensions: *Base sizes:* Various sizes available

III. Assembly and Start-Up:

The Model 4040™ Platform Scale is shipped partially disassembled. Assembly instructions are as follows:

The load cells are secured to the base. All wire connections in the base have been made and sealed at the factory. The digital weigh meter is assembled and calibrated to the base at the factory. The customer must mount the indicator on the wall. The base should be roughly leveled using the adjustable foot in the load cell. The wires must be run through the strain relief and connected to the connector before scale is operated. Steps are as follows:

Step 1: Remove all parts from box and inspect for damage – bent metal, broken wires, cracks in indicator, etc. Any shipping damage must be reported **to carrier!**

Step 2: Place the scale on a solid, dry, and even surface. Clear the area of all debris where the scale base will be anchored. The "foot" that is in the load cell is adjustable with a nut to tighten. Level the base by adjusting this foot, and then use the nut to tighten the foot so that it cannot move.

Step 3: If conduit is to be used, we recommend at least 2 feet of FLEXIBLE conduit as to not interfere with free movement of the base for accurate measurement. Feed the wire up through the conduit, and apply a fitting.

Step 4: Drill a hole in the indicator, being sure to avoid the PC board, and completely seal the hole with the fitting. ***If ANY SPACE exists around the fitting allowing gas into the box, the equipment will be damaged. You MUST SEAL any openings with a flexible caulk, such as silicon!*** Fasten the indicator to the wall. Connect the wires into the connector using the following code:

TB1 : Ret: Common, 4-20mA Return*

Out: + 4-20mA Output*

G: Green = + Signal

W: White = - Signal

Bk: Black = - Supply Voltage

R: Red = + Supply Voltage

*Connect your wires here if you are using 4-20mA output. Refer to the wiring diagram on page 5 and 6 for 4-20mA connections. Jumper J-4 will need jumper in the top two pins for loop powered, and the bottom two pins for scale powered (with board oriented as in drawing pg 5.)

Insert the wire, being sure not to crimp the insulation in the connector. Using a small screwdriver, push the orange lever down to insert the wire into the proper hole and release the lever to allow the wire to clamp into the connector. The connector holes are labeled according to the color that is inserted there.

Step 5: Allow approximately 15 minutes warm up time before using the scale.

IV. **General Use Instructions:**

Please refer to these instructions for daily use of this scale. These instructions simulate the procedure for every day usage.

ON AND OFF LOADING USAGE:

To start with a new, FULL tank that will be loaded on & off, please follow these steps:

Please choose a method of usage by Tare or Net Weight:

TARE: You must know the weight of your empty tank, and any other equipment mounted on to the tank that will affect the weight. Add this weight together, and turn the black tare knob on the front of the indicator until it reads that number in the negative. Turn the knob counter-clockwise in order to achieve negative numbers. Once that negative tare weight is set, you may load the tank, and apply other equipment on that tank. The weight that registers on the scale indicator is the NET WEIGHT, or weight of the contents. At this point you will not change the black tare knob unless you are loading on a new tank. As you use the contents, the weight decreases. When the tank is at zero, or close to it, you will begin again by removing the empty tank, setting the tare weight with the black knob (for the new tank + equipment), and begin using the material again.

NET: If you do not know the tare weight (it is not stamped on the tank), you may know the Net Weight (contents in the tank). If this is the case, you will use this procedure:

Load on your full tank and attach any equipment that affects the weight on the scale. Turn the black tare knob on the front of the indicator until it reads the known NET WEIGHT (weight of contents only) on the indicator. Clockwise will increase the readings and counter-clockwise will decrease the readings. When the weight is set for the contents in the tank, do not adjust this again until you load on a new tank. The reading will decrease until you have used all the contents in the cylinder, where it will read 0 lb./kg. Start a new tank by removing the old empty tank, loading on a new full tank, and attaching equipment, and set tare knob to Net weight again.

For use when FILLING the TANK instead of on & off loading:

To start with a new, EMPTY tank that will be filled while on the scale base, please follow these steps:

Load the new, empty tank on to the platform. Be sure to connect all equipment to the tank that may apply weight to the scale. With this weight applied, turn the black tare knob located on the outside, front of the indicator, until the digital reading says zero. This means that your digital reading will show net weight, or the weight of the contents alone. As you fill the tank for the first time, the scale shows the current weight at all times. Do not readjust the tare weight unless you are starting with a dry, new, empty tank. Any residual weight will reflect what is left in the tank, and should not be changed unless a new tank is put on the base.

V. **Calibration Procedure:**

The Model 4040™ Platform Scale is ***pre-calibrated at the factory to within specified accuracy and is calibrated to standards traceable to the Bureau of Weights and Measures. No further calibration should be necessary. If the electronics or load cells in the base are being replaced, the following procedure should be used.***

1. Plug the AC Cord into a well-grounded receptacle. There is no power on / off switch, so power is applied as soon as it is plugged in.
2. Allow approximately 15 minutes warm-up time before calibration.

3. While indicator is warming up, proceed to check under cylinder support disc to make sure there is no debris.
4. WITH NO WEIGHT APPLIED TO THE SCALE, turn the black tare knob on the outside of the door of the indicator in the clockwise direction to make sure that there is *at least* +10 lb. of weight in the tare knob. If not, adjust R-6 to see a positive reading. Once that is established, turn the black tare knob on the door of the indicator counter-clockwise until it stops (DO NOT OVER TURN KNOB OR YOU WILL DAMAGE THE TARE POT!) Once it reaches the most negative reading, make sure you have at least the amount of tare weight that you require for the tanks/drums that you will use on this platform. If the tare span is very large, you may get to a -1 reading and this is a weight under-load condition. Turn R-6 until you see a number a number that is not "below" -199.9 lb or 1999 lb.
5. Adjust tare knob on front of weigh meter until scale reads zero with no weight on platform. Adjust R-22 to set the 4mA reading to 0lbs.
6. Place a known weight on the disc, as close to center as possible. Weight should be equal to ½ of capacity, or greater.
7. Adjust R-15 until display reads weight of test weight on scale disc.
8. To complete calibration of 4-20mA output, adjust R-19 for proper 20 mA adjustment reading. The customer specifies the factory setting for 20 mA at the time the order is placed. It should have been assigned to the net weight of your intended product. Consult white "4-20mA settings" sticker on inside of indicator!
9. Calibration is complete if specified accuracy is obtained.

VI. Troubleshooting:

1. If display reads: "-1":

- A. Gross under-load. Turn knob clockwise. Numbers should reappear and can be adjusted to tare weight or zero as required.
- B. Check load cell connections at indicator, and connect wires as per diagram on Page 5.

2. If display reads: "1":

- A. Gross over-load. If starting point was zero, the cylinder weight is more than 199.9 lb., or kg. with the decimal, or 1999 lb./kg. without the decimal.
- B. Check load cell connections according to page 2.

3. If no display (not lit):

- A. Check power to weigh meter.
- B. Check green light on power supply board. It should be lit. If not lit, it is shorted out.

4. Other Problems:

- A. Consult the Factory!

USA & Canada Toll-Free: (800) 257-5911
Tel: (+1) 215-766-2670 ♦ Fax: (+1) 215-766-2672

Notice: Do not return any equipment without first contacting the factory. A return authorization number will be issued and it must be marked on all materials returned to the factory, accompanying a letter that explains the problem specifically. A Serial Number will also be required. It is located inside the indicator box.

VII. Board Diagram:

3 1/2 digit LCD Board

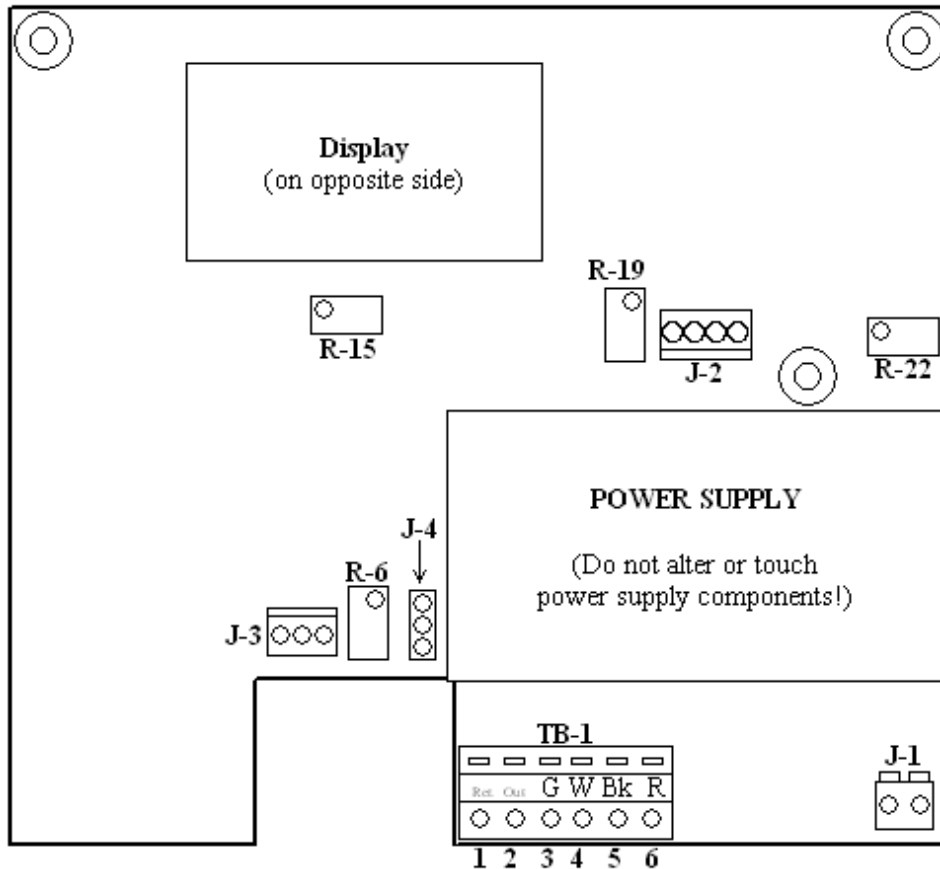

From left to right with P.C. Board as shown, the following connections should be made:
 (Connector is identified with positions 1-6 from left to right, but is not labeled on the p.c. board.)
 Sticker on connector identifies the color wires from the base to connect to TB-1.

TB-1:

- 1 - (Ret) Common, 4-20mA return
- 2 - (Out) + 4-20mA Output
- 3 - Green = G = + Signal
- 4 - White = W = - Signal
- 5 - Black = Bk = - Supply Voltage
- 6 - Red = R = + Supply Voltage

J-1 - Voltage (AC) line connection

J-2 - Optional Low Level Board connection

J-3 - Tare Pot connector

J-4 - Top two pins jumpered for Loop Powered 4-20mA,
 Bottom two pins jumpered for Scale Powered 4-20mA.

R-6 - tare adjustment

R-15 - weight span

R-19 - 20mA adjustment

R-22 - 4mA adjustment

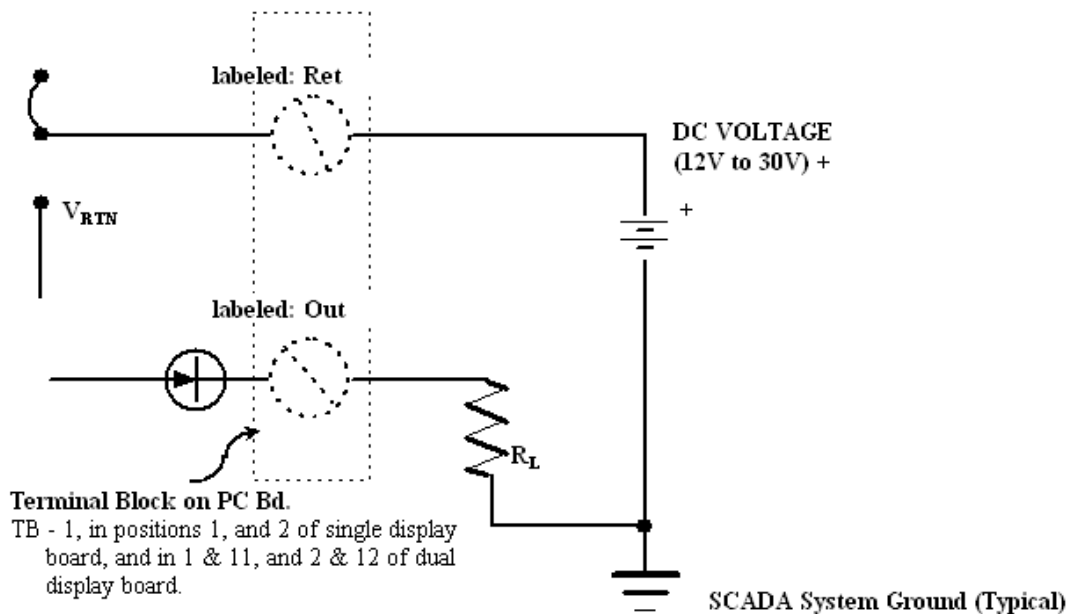
4-20mA Diagram:*Refer to appropriate diagram:***LOOP POWERED DIAGRAM****SCALE POWERED DIAGRAM**